

Tamil Nadu Handloom Weavers' Co-operative Society Limited

**PRE-QUALIFICATION APPLICATION AND
PRICE TENDER TWO COVER SYSTEM**

NAME OF WORK : Construction of Marketing Complex at Co-optex
Regional office, Tirunelveli in Tirunelveli District .

EMD AMOUNT : **Rs 1,53,000/-**

DATE OF TENDER : **27.10.2018**

ISSUED TO :

The Managing Director
Tamilnadu Handloom Weavers'
Co-operative Society Limited

FOR THE SPECIAL ATTENTION OF THE APPLICANTS

1. Issuance of documents under two cover system i.e. qualification tender and price tender(commercial tender) to the applicant will be purely based on the basic Documents and information furnished along with the requisition and cost of tender documents Application will not confer any right on the Applicant for automatic qualification for price tender for the work.
2. Approval or otherwise of the qualification tender will be strictly based on the detailed evaluation done on the basis of the Documents / Records / Evidences / Certificates produced by the Applicant in the Qualification Application.
3. Pre-Qualification tender schedule (cover I) will be opened as per Notice inviting Tender and after detailed evaluation , the date and time of opening of price tender will be intimated to the qualified applicants
4. “The evidences on the minimum qualification criteria mentioned under ‘part-II Information and Instructions for the Tenderers’ under two cover system prescribed with application should be furnished in Cover-I without any lapse at the time of submission of pre-qualification tender itself. Any lapse in this regard, will be summarily rejected”.

The Managing Director
Tamilnadu Handloom Weavers’
Co-operative Society Limited

TWO COVER SYSTEM**PRE-QUALIFICATION TENDER & PRICE TENDER APPLICATION**

From

To

The Managing Director
TNHWCS Limited
Chennai:- 600 008.

Sir,

Sub:- Two cover tender system for the work of Construction of Marketing Complex at Co-optex Regional office, Tirunelveli at Tirunelveli in Tirunelveli District .

Ref:- Pre-Qualification & Price tender Notice No.

1. Having examined the two cover system documents in respect of Pre-Qualification tender & Price tender including scope of work, Time Frame for construction and the criteria stipulated for pre-qualification. I / We hereby submit all necessary information and relevant documents for qualifying me /us, to offer my / our tender for the above mentioned work.
2. The Pre-qualification Application is made by me / us on behalf of (Partnership firm / Private limited company / Public Limited Company) in the capacity of duly authorized to submit the tender.
3. Necessary evidence admissible in law respect of authority assigned to me / us on behalf of the Partnership Firm / Private Limited Company / Public Limited Company, for applying for qualification tender is attached herewith.
4. I / We present my / documents herewith taking into consideration all the instructions in the Qualification tender supplied to me / us including special instructions to Applicants /criteria for Qualification schedule / Information and Instructions in the detailed two cover notice etc.
5. The EMD amount is enclosed in the shape as notified in the pre-qualification tender.
 - I.
 - II.
 - III.

Contractor

Managing Director,
T.N.H.W.C.S.LTD,CHENNAI

6. I / We understand that The Managing Director reserves the right to reject any or all the tenders without assigning any reason therefore or to drop the proposal altogether as detailed in the Tamilnadu Transparency in Tender Act 1998.

Date :

Signature of the Applicant including
Title Capacity in which Application is made

Name:

(IN BLOCK LETTERS)

- Encl:
1. Pre-Qualification two cover tender system
Pre-Qualification tender and price tender.
 - 2.
 - 3.
 - 4.
 - 5.

APPLICATION FOR PRE-QUALIFICATION & PRICE TENDER NOTICE
(TWO COVER SYSTEM)

FORM OF CONTRACT : LUMPSUM AGREEMENT

TWO COVER SYSTEM

1. INVITATION :

Tender under sealed two cover tender system i.e. qualification schedule & Price tender (Item rate tender) are invited for and on behalf of the TNHWSC Ltd by The Managing Director TNHWCS Ltd Chennai. One cover contains EMD and Qualification conditions and other details and the Second over containing price tender schedule. The above two covers shall put into one sealed cover at the time of submission of Tender.

2. FOR SPECIAL ATTENTION :

- I. Only the Contractors registered with Tamil Nadu State Public work Department under **Class I** (State level as per revised classification) with monetary limit above **Rs.75.00 lakhs (Rupees Seventy Five Lakhs)** and with Proven track record are only eligible. In such a case the applicant should furnish the following documents to satisfy the Criteria
- II. The Applicants should have been in the same name and style in the civil Engineering Construction field at least for the past FIVE years.
- III. The Applicants should have completed at least one “ **Building**” work of similar nature with value of not less than **Rs.100.00 lakhs (Rupees One hundred lakhs only)** under a “**Single agreement**” in any one of the preceding “**Five**” years. (From 2012-13 to 2016-17) For this purpose buildings like Industrial sheds, workshops will not be considered.
- IV. Annual turnover of the Applicant should not be less than **Rs.350.00 Lakhs (Rupees Three hundred and fifty lakh only)**

3. PURCHASE OF DOCUMENTS :

- a) The documents under two cover system Qualification schedule & price tender will be available for sale at a cost of **Rs. 15,000/- plus GST 18%)** in the office of TNHWCS Ltd , 350 Pantheon Road, Egmore, Chennai. During office hours from **27.12.2018 to 10.01.2019** upto **3.00 P. M.** The above said qualification schedule and price Tender can also be downloaded from the appropriate website free of cost which are also eligible for tendering purposes.

- b) The qualification schedule and price tender schedule will also be sent by post to any Prospective tenderer who makes a request for the documents on payment of cost as specified in para 3.a. along with postal charges of Rs.500/- (Rupees Five Hundred only) separately in the shape of Demand Draft drawn in favour of TNHWCS Ltd obtained from any Nationalized Bank / Scheduled Banks and documentary evidences. This office is not responsible for any postal delay or loss in transit.
- c) Price Tender Schedule will also be issued along with pre-Qualification schedule documents.

4. DESCRIPTION OF PROJECT :

Construction of Marketing Complex at Co-optex Regional office, Tirunelveli Region at Tirunelveli in Tirunelveli District .

5.SCOPE AND STATUS OF THE WORK UNDER THIS TENDER :

SL. No	Components	Plinth area	CA Job No
1	<u>Stilt Floor</u> Car Parking, Electrical Panel Room, Staircase etc.,	393 m ²	
2	<u>First Floor</u> Co-optex Showroom, Godown, Toilet, Staircase etc.,	400 m ²	

6.PERIOD OF COMPLETION :

The period of completion shall be 12 (**Twelve**) months – which is inclusive of monsoon period from the date of handing over the site to the successful contractor.

7.EARNEST MONEY DEPOSIT :

7.1 Earnest money deposit of **Rs.1,53,000/- (Rupees One lakh fifty three thousand only)** must accompany the Pre Qualification Tender for this work.

7.2. The Earnest money deposit may be produced in any one of the following forms.

I. Demand Draft, Bankers Cheque Issued by Nationalized or Scheduled Banks drawn in favour of the TNHWCS Ltd

Contractor

Managing Director,
T.N.H.W.C.S.LTD,CHENNAI

- 7.3 Qualification schedule not accompanied with Earnest money deposit will be rejected as 'Non – responsive' tender.
- 7.4 If the tenderer withdraws his tender after the acceptance of tender or fails to pay the requisite security deposit amount within the specified period of time, the Earnest money deposit paid by him with the tender will be forfeited.
- 7.5 Communication to the unsuccessful tenderers will be sent in 7 (seven) days time from the date of communication sent to the successful tenderer within 15 (fifteen) day from the date of receipt of refund vouchers duly stamped and signed from the unsuccessful tenderer, refund of Earnest money deposit will be made along with an open price tender

8. SECURITY DEPOSIT :

- 8.1 The successful tenderer shall furnish a Security Deposit for an amount equivalent to 2% of the contract value, which includes the earnest money deposit already paid within 15 days (Fifteen days) from the date of receipt of work order. If the successful tenderer fails to execute the contract (i.e. sign the agreement) within the above said 15 days time, the Earnest Money Deposit amount enclosed with the qualification schedule will be forfeited
- 8.2 The Security Deposit in the shape of irrevocable Bank guarantee will also be accepted.
- 8.3 In addition to the aforesaid security deposit, the Departmental Engineer. shall deduct from the running account bills, an amount equivalent to 5% (Five Percent) of the total value of each bill as retention money.
- 8.4 2½ % (TWO AND A HALF PERCENT) of the total value of the work will be retained in the final bill of the work for a period of one year reckoned from the date of completion of the work or as soon after the expiration of such period of one year as all defects shall have been made good according to the true intent and meaning hereof which ever shall last happen.
- 8.5 The retention money of 2½ % (Two and a Half Percent) of the total value of contract after deducting any amount due to the Department, shall be refunded to the contractor after the defects liabilities attached to the contract is over (as per Para 8.4 above) subject to the following conditions
- i) The Department of Engineer concerned should certify that no liability is due from the contractor.

- ii) The Contractor should execute and produce an indemnity bond for a further period of “FOUR” years indemnifying the Government against any loss or expenditure, incurred to rectify any defects noticed due to Faulty workmanship by the contractor, during the period of “FOUR” years.

8.6 Concessions granted to standing contractors on payment of deposits are not applicable to this contract.

9. LANGUAGE OF TWO COVER TENDER SYSTEM :

Tenders shall be offered only in the prescribed forms in “ENGLISH” only

10. VALIDITY OF PRICE TENDER :

The Pre-Qualification application & Price tender shall be valid for a period of 90 days (Ninety Days) from the date, notified for opening of Pre-qualification tender.

11. SUBMISSION OF PRICE TENDER SCHEDULE BY TWO COVER SYSTEM

- 11.1 Tenderers should quote their rates both in figures and in words for each item per unit and amount for each item of work for full quantity. Grand total of the whole contract should be furnished without fail in the last page of schedule “A” of price tender.
- 11.2 The two cover (i.e. Qualification schedule and price tender shedule) must be submitted in a wax sealed envelope, The cover No.1. containing the Qualification schedule,(called as inner envelopes) documents & Earnest Money Deposit and cover No2. containing the price tender must be super scribed as mentioned below and addressed to the tender calling authority.

PRE-QUALIFICATION SCHEDULE

COVER NO.1	PRICE TENDER	COVER NO.2.
a. NAME OF WORK		a. NAME OF WORK
b. TENDER NOTICE NO.		b. TENDER NOTICE NO.
c. DUE DATE FOR OPENING OF TENDER		c. NAME OF CONTRACTOR AND ADDRESS
		d. DATE OF TENDER
d. E.M.D Rs.1,53,000/- (Rupees One lakh fifty three thousand only) (To be furnished with the qualification schedule)		
e. NAME OF THE CONTRACTOR AND ADDRESS		

These two inner envelopes shall be put inside a sealed common cover and superscripted with all the details as with that of Cover I and addressed to The Managing Director TNHWCS Ltd., Chennai.

11.3 If the cover is not sealed and super scribed as instructed, no responsibility will be assumed for any misplacement of tender or premature opening of the envelope or parcel.

11.4 Tenders received late on any account or any reasons whatsoever will not be opened or considered and will be returned to the tenderer unopened.

11.5 Telegraphic tenders will not be accepted.

12. OPENING OF TENDERS :

The common cover and first cover containing Qualification schedule will be opened by The Managing Director TNHWCS Ltd Chennai at **04.00 P.M , on (10.01.2019)** notified date in the presence of the tenderers or their authorized representatives who choose to be present; after detailed evaluation of qualification schedule on pass or fail basis of qualification schedule. Price tender of the qualified contractors only will be opened those who satisfy the minimum criteria. The date and time of opening of price tender will be informed to the qualified

Contractor

Managing Director,
T.N.H.W.C.S.LTD,CHENNAI

tenderers by The Managing Director later. The price tender cover of the unqualified tender will be returned to them unopened.

13. NEGOTIATION :

Negotiation of rates will be made only with the lowest tenderer for reducing the quoted rates.

14. RATES AND PRICES :

**Price Adjustment Clause, Bonus Clause, Liquidated Damages etc.,
Price adjustment clause is eligible for this work subject to the following:**

Full Price adjustment on all the components is application as per specification formula

Price adjustment will apply only when the fluctuation of rates exceeds by 3% compared to the estimate rates (Reserve Bank of India – Index Price)

Price adjustment will be calculated only on the estimated cost of work.

Bitumen and POL will be considered on “pass through” basis with payment of actual rates/ price at the rates charged by Indian Oil Corporation.

Price adjustment will be made for both **increase and decrease** in the cost of materials.

Price variation will be calculated once in a quarter in respect of cement and steel as per specified formula from the last date of submission of tender upto the end of agreement period. Provided, if the agreement is signed within minimum specified time, failing which, the price variation will be applicable from the date of agreement only, based on the whole sale Price indexes of RBI.

For the purpose of calculating price adjustment, the quarter would be reckoned with reference to the quarter of the calendar year in which the last date on tender submission is fixed. In case of delayed agreement the quarter in which the agreement signed will be reckoned for the purpose of calculation of Price adjustments.

Price escalation will be calculated based on milestones fixed in physical terms and prefixed timeline for usage of inputs, clearly indicating the nature and quantum of eligible inputs to be used for the work for the relevant period between two milestones.

Escalation will be given for only those quantities which would have been used had the contractor stuck to this original time line.

If the contractor does a certain quantity of the work in the third quarter which he should have done in the second quarter, he can still claim escalation on that quantity at the rates as applicable in the second quarter or Period of actual use whichever is less.

Price adjustment mechanism will cease to operate for the value of work executed beyond the agreement period. But agreement period shall include the “actual period” for which the work was “suspended officially” and extension of time permitted for any valid reasons, such as, war, natural calamities, like flood, earthquake and other risks arising out of acts of God during the agreement period; work delayed due to the land acquisition process; change in design change in scope of work, etc., which is given in writing by the Tender Calling Officer of the respective work.

Bonus as an incentive for advance completion of work by not less than 10% of agreement period will be paid at 1% on the value of actual quantum of works executed at tendered rates.

15. WHOM TO CONTACT :

The Managing Director, TNHWCS Ltd Chennai may be contacted for further information in the matter.

Dated signature of the Applicant
With seal

The Managing Director
TNHWCS Ltd

INFORMATION AND INSTRUCTION FOR TENDERERS UNDER TWO COVER SYSTEM

I. FOR SPECIAL ATTENTION :

Pre Qualification Application here under is invited in accordance with the Tamil Nadu state Public work Department procedures for Qualification of Tenderers.

The tenderers should submit their documents in support of their credentials at the time of tendering it self. The submission of particular to establish their qualification criteria for items 1 to 6 are mandatory, otherwise the tender will be

Contractor

Managing Director,
T.N.H.W.C.S.LTD,CHENNAI

summarily rejected without any consideration.

II MINIMUM CRITERIA FOR PRE QUALIFICATION :

1 (a) The Applicant in the same “NAME” and “STYLE” should have been in the civil Engineering construction field atleast for the past “FIVE” years.

1. (a) EVIDENCE TO BE PRODUCED :

- i) Audited Balance sheet with Chartered Accountant’s Certificate for the past “FIVE” years in the case of individual Contractor’s, Partnership Firms, Private / Public Limited companies.
- ii) Registered Partnership deed in the case of Partnership Firms.
- iii) Articles of Association and memorandum of Association registered with Registrar of Companies as per company act in the case of Private Limited Companies and Public Limited Companies.

1. (b) The Applicant should be a Registered contractor of Tamil Nadu state Public work Department under **Class I (State level)**, as per revised classification with monetary limit above **Rs.75.00 Lakhs (Rupees Seventy Five Lakhs)** with proven track record.

1. (b) EVIDENCE TO BE PRODUCED :

1. Attested copy of the communication issued by the Registering Authority, registering the name of the Applicant as **Class I** Civil contractor in Tamilnadu State Public works Department as per Revised Classification and Live Certificate.

1 (c) The Applicant shall be solvent to a tune of at atleast Rs.31 Lakhs (Rupees Thirty one Lakhs only) on immovable Properties.

1. (c) EVIDENCE TO BE PRODUCED :

- i) Current Revenue Solvency Certificate for not less than **Rs. 31.00 Lakhs (Rupees Thirty one Lakhs only)** issued by Tahsildar concerned within three years prior to the date of tender. (ie 27.12.2018)
- ii) Continuous Encumbrance Certificate issued by the Registration Department on the Properties listed out in the Solvency Certificate for the period from the date of Solvency to the date of publication without any break.

- iii) If the date of solvency certificate is on or after the date of publication, Encumbrance Certificate need not be produced.

1. (d) The Applicant should produce Income Tax Clearance Certificate valid for the current period & Sales Tax Registration details either State or Central and GST Verification Certificate valid for the current period and GST Number.

1. (d) EVIDENCE TO BE PRODUCED :

- i. Income Tax Clearance Certificate issued (or) Saral form by Competent Income Tax Department officials valid for the current period, duly attested.
- ii. The Income Tax claimed and paid during the past “FIVE” years and the total contract amount received in the past “FIVE” years should have been indicated in the Income Tax Clearance Certificate.
- iii. Attested copy of Registration Certificate showing the TNGST / CST Number assigned by the Commercial Tax Department issued by the Competent State / Central Commercial Tax Department officials.
- iv. Attested Photocopy of the GST verification certificate for the current period issued by competent State / central Commercial Tax Department officials.

1 (e) The Applicant should furnish the details of major building works and other civil works completed during the past “FIVE” years.

1. (e) EVIDENCE TO BE PRODUCED :

List of major building works and other civil Engineering Construction works completed in the past FIVE years with full complete details such as

- (I) Name of work
- (II) Value of work
- (III) Name of Employer for whom the work was executed
- (IV) Agreement Number
- (V) Period of Completion as stipulated in the agreement
- (VI) Time taken for completing the work
- (VII) Reasons for delay if any
- (VIII) Type & Nature of work
- (IX) Certificate issued by the competent authority.

Necessary certificates issued by the competent authority not below the rank of on the satisfactory completion of the work should be furnished in support of the details furnished by the applicant.

Details furnished without supporting certificates will not be considered.

- 2 The applicant should have satisfactorily completed at least one “**Building**” work of similar nature with value not less than **Rs.100.00** lakhs (**Rupees One hundred lakhs** only) under a single agreement either in Govt. or in quasi Govt. or and in private which is certified by the Executive Engineer or Head of Department incharge of that jurisdiction, in any one year of the preceding five years . For this purpose buildings like Industrial shed, workshop will not be considered.

2. EVIDENCE TO BE PRODUCED :

1. Certificate issued by the Engineer – in – Charge – (Not below the rank of Executive Engineer / Project Engineer) – of the work clearly showing the following details.

- a. Name of work
 - b. Location of the work – (Town / Taluk / District / State)-
 - c. Name / Designation of the Employer / owner
 - d. Value of work – (As per Agreement)-
 - e. Agreement Number
 - f. Stipulated period of contract as per agreement
 - g. Date of commencement of work
 - h. Date of actual completion of work.
 - j. Reasons for delay in completing the work ,if any
 - k. Actual value of work as per final payment made
 - l. Quality of work executed.
 - m. For works under execution certificate from the Executive Engineer for the evidence for the portion of work done and its value to be furnished.
3. Annual turnover of the applicant shall be not less than **Rs.350.00 lakhs (Rupees Three hundred and fifty lakhs only)** in any FIVE years of his total career.

3. EVIDENCE TO BE PRODUCED :

- i Audited Balance sheet ,Profit and loss Account etc., duly certified by the Chartered Accountant for the preceeding “FIVE” years.
 - ii The Total contract amount received as shown in the Balance Sheets should have been reflected in the Income Tax Clearance certificate also, in case there is difference in the contract amount received as depicted in the Balance sheets and as furnished in the Income Tax clearance Certificate ,lesser among the two figures alone will be taken for consideration.
- 4 The applicant should have a minimum issued and called up Share capital plus capital reserves equal to at least 20% of the value of work for which prequalification tenders & price tender have been called for – (In this case 20% value of the work is **Rs.31 lakhs (Rupees Thirty one lakhs only)**)

4. EVIDENCE TO BE PRODUCED :

- i Audited Balance sheet for the preceding five years duly certified by the Chartered Accountant.
- ii The amount indicated in the Audited Balance sheets as
 - a. Paid up Share Capital In the Case of Private /
 - b. Called up and subscribed share Capital Public Limited Company
 - c. Partner’s Capital Account in the case of Partnership firm
 - d. Individual Capital Account in the case of individual Contractors.

AND

- e. Reserves and Surplus Available in Capital account (to be furnished separately)alone will be taken as amount available as paid up share capital / called up subscribed share capital.
- 5 The applicant shall have working capital available atleast sufficient to finance one – month current activity on the assumption that this work is awarded to the applicant, on being qualified.

Definition

- a Working capital means the amount available in the Bank Accounts of the applicant on the date of submission of applicant plus the unutilized amount of overdraft / credit facility extended to the applicant by the Nationalised / Scheduled Banks.

- b One month current activity means the sum total of the value of the unfinished portion of works already committed by the applicant and being executed by the applicant – (out standing value)- divided by the Balance period available for completion of each of the committed works under execution plus the value of the work for which the qualification schedule & Price tender is called for divided by the number of months stipulated for its completion.
- c Outstanding value of committed works means the total value of each project under execution minus the value of work completed as on the date of submission of qualification application.

EVIDENCE TO BE PRODUCED :

- a List of works already committed by the applicant and are in progress
- b Certificate – (for each of the committed works) – issued by the Engineer – in-charge- (Not below the rank of Project Engineer) – of the work, being executed by the applicant with the following details.
 1. Name of work
 2. Name / Designation of the Owner / Employer
 3. Agreement Number
 4. Total Value of the work
 5. Period of completion stipulated in the agreement
 6. Date of commencement of the work
 7. Balance period available for completing the work
 8. Value of work so far completed
 9. Value of Balance items of work to be completed.
 10. Physical progress or stage of work
 11. Remarks
- c Certificate issued by Bank / Banks / showing the amount available (on the date of submission of application) in the current Account / Savings Bank Account of the applicant .
- d Certificate issued by the Bank / Banks / showing the limit up to which overdraft / credit facilities is extended to the applicant and the overdraft / Credit facility by the applicant up to date and the unutilized overdraft / credit facility available.

NOTE :

Fixed Deposit in the name of the “Applicant” will also be considered for the purpose of working capital, on production of “Certificate” issued by the Respective

Contractor

Managing Director,
T.N.H.W.C.S.LTD,CHENNAI

Banks, clearly Stating that the Fixed Deposits are available in the Name of the “Applicant” and the same are “Encumbrance Free” and can be readily “Encashable”.

7. The applicant should not have any of his contracts terminated / rescinded due to breach of contract on the part of the applicant during the past “FIVE” years by any agency.

EVIDENCE TO BE PRODUCED :

(I) Sworn in affidavit duly certified by Notary Public , is to be produced (Specimen appended) – in twenty rupee Non- Judicial stamp paper.

8. The applicant shall have a Project Manager together with site Engineers with B.E., (Civil) Degree in civil engineering or Diploma holders in civil Engineering with minimum field experience, noted against each, available as given below, exclusively for this work.

1. Project Manager : **1 No** - (One Number) B.E., (Civil) Degree in Civil engineering with at least ten years Experience in executing similar works .

2. Site Engineers : **2 Nos** - (Two Numbers) – B.E., Degree in Civil Engineering with atleast three years experience.
and
: **3 Nos** - (Three Numbers) Diploma in civil Engineering With atleast three years experience.

3. Skilled and unskilled work men : Adequate Numbers.

DOCUMENTS TO BE PRODUCED :

- i List of Technically Qualified personnels under permanent / Regular employment available with the Applicant with details such as (a) Name (b) Qualification (c) Total experience (d) Under regular Employment with the applicant since -----(e) Emoluments paid etc.
- ii List of Technical personnels to be deployed for this work along with their willingness & attested Xerox copy of the testimonials in support of the qualification of the personnel to be deployed.
- iii If required number of Technical Personals are not under Regular Employment of the applicant, Name Qualification, Experience etc., of the

Technical personnel to be employed for this work along with their willingness and attested Xerox copy of the testimonials in support of the qualification of the Technical personnels proposed to be employed exclusively for this work should be furnished.

9.The applicant shall have the following minimum construction equipments Tools and Plants exclusively available for this work. – (Either own or under lease with the applicant)

1. Concrete Mixer Machine with Hopper : 4 Nos- (Four Numbers)
2. Vibrators : 4 Nos-(Four Numbers)
3. Dewatering Pumps : 4 Nos - (Four Numbers)
4. Lorry / Tipper : 2 Nos (Two Numbers)
5. Steel centering Materials to cover an area of : 2000 sq.m (Two thousand square Meters.)
6. Mechanical spray set for curing : 3 Nos (Three Numbers)
7. Mechanical Hoist : 1 No (One Number)
8. Poclain / JCB : 1 No (One Number)

DOCUMENTS TO BE PRODUCED :

- i Attested Xerox copy of the R.C.Books for the Machineries / Vehicles owned by the applicant.
- ii Sworn in affidavit and Chartered Accountant's Certificate stating the details of equipments, tools and plants available with the applicant with make year of purchase, capacity, present working condition of the equipment etc.,
- iii If the Tools and plants are proposed to be taken on lease or already on lease with the applicant, the source from which the Tools and plants have been taken on lease or proposed to be taken on lease with proof, should be furnished in addition to the Particulars in item-ii-.

NOTE

- 1 If any of the information furnished by the applicant is found to be concealed or false at a later date, the contract will be terminated forthwith without Prejudice

Contractor

Managing Director,
T.N.H.W.C.S.LTD,CHENNAI

to the rights thereon consequent on termination and the contractor will be banned from business dealings.

- 2 All the documentary evidences should be stitched neatly (Spiral Binding should be avoided) and the pages should be serially numbered, Index of the Documents produced should be prepared and reference to page number of the documents produced should be furnished in the index.
- 3 The Qualification schedule evaluation shall be done on a PASS or FAIL basis against each of the above 8 (Eight) criteria.
- 4 The evaluation will be done only based on the information evidence, documents, Records, Particulars furnished by the applicant and hence the applicants are advised to furnish adequate and relevant information along with requisite documentary evidences without any omission.
- 5 As far as possible, details shall be furnished in the schedules appended to this Application. If the space left is found insufficient, additional sheets may be attached to the schedules.
- 6 Photograph of the building works completed by the applicants may be pasted in thick white paper and produced along with the documents.
- 7 Brochures, Pamphlets etc, shall also be stitched along with the documents volume.
- 8 All applicants are cautioned that the Qualification schedule documents containing any deviation from the contractual terms and conditions, specifications or other requirements will be rejected as Non – Responsive and low performance reliability.

III METHODS OF TENDERING :

- i If the Pre Qualification application is made by an individual, it should be signed by the individual, with his full name and his current address.
- ii If the Pre Qualification application is made by a sole proprietary firm, it shall be signed by the proprietor along with his full name and full name of the firm with it's current address. Documents with regard to registration as FIRM by the Registrar of Firms should be Produced.
- iii If the Pre Qualification application is made by a FIRM in partnership, it shall be signed by all the partners of the firm with their full names and

Contractor

Managing Director,
T.N.H.W.C.S.LTD,CHENNAI

current address or by a partner authorized by the firm (either as per Articles of the Deed of Partnership / by power of attorney) – for signing in Tenders, Agreements etc. In which case, certified copy of the Registered deed of partnership along with the current address of all the partners and a certified photocopy of the Registered power of Attorney issued in favour of the Signatory, should produced.

- iv If the Pre Qualification Application is made by a “ Limited Company” or a “Limited Corporation ” it shall be signed by a duly authorized person holding the power of attorney for signing the application, in which case, the certified copy of the power of attorney shall accompany the qualification application . Such limited company or corporation shall also furnish satisfactory evidence of its existence along with the Pre Qualification Application.

v **PRE-QUALIFICATION APPLICATION FROM JOINT VENTURES ARE NOT ACCEPTABLE.**

- vi All the signatures in the Qualification Application and all the signatures in the Documents produced **Shall be dated**

- vii All the originals of the documentary evidences shall be produced, If asked for, for verification at the time of opening of Qualification schedule .

IV. CAPABILITY OF APPLICANT :

The Applicant shall include with the Qualification schedule, details in the prescribed Proforma vide schedule “A” to “H”.

- i. Schedule ‘A’ - Structure and Organization.
- ii Schedule ‘B’ - Financial Capability statement
- iii Schedule ‘C’ - Plant and Equipments
- iv Schedule ‘D1,D2 & D3’ - Work experience (Works completed & Works in progress)
- v Schedule ‘E’ - Abandonment of work
- vi. Schedule ‘F’ - Affidavit
- vii Schedule ‘G’ - Undertaking
- viii Schedule ‘H’ - Details of Technical Personnel under Regular Employment with the Applicant.

V.OPENING OF QUALIFICATION SCHEDULE & PRICE TENDER SCHEDULE

- i Pre-Qualification schedule & price Tender schedule will be received in sealed cover (Separately) upto **03.00 P.M on 10.01.2019** Qualification schedule will be opened on the same day at **04.00 P.M** by The Managing Director TNHWCS Ltd /Tender Committee. in the presence of the applicant or their Authorised representatives (who should produce the authorization issued by the firm / Company) who choose to be present.
- ii The Pre-Qualification schedule cover received will only be opened and evaluated on a PASS or FAIL basis against each of the 8 (Eight) Criteria in Para II above.
- iii The Pre-Qualification schedule and price Tender Schedule received belatedly on account of any reasons whatsoever will not be opened or considered and will be returned unopened to the applicant.
- iv Telegraphic Applications will not be entertained.
- v The date of opening of Price tender will be notified to the qualified applicants after evaluation of qualification schedule well in advance.

Dated signature of the
Applicant with seal

The Managing Director
TNHWCS Ltd

Schedule "A"
STRUCTURE AND ORGANISATION

1. Name of the Applicant :

2. Status :
 - Individual contractor :
 - Sole proprietary Firm :
 - Firm in Partnership :
 - Private Limited Company :
 - Public Limited Company :

3. Head office / Registered office address with phone / Telex / Fax Number. :

4. Regional office address with phone / Telex / Fax Number :

5. Local office (if any) address with phone / Telex / Fax Number. :

6. Field of activity of the Applicant as per deed of Partnership / Memorandum of Association / Articles of association (Civil) Engineering Contractor / General Engineering contractor / Electrical Engineering contractor etc., should Be specified). :

7. Country and year of incorporation. :

8. Main line of Business :

9. Name, Position, status, capacity etc., of the key personnel / Directors of the company (Attach organization chart showing the structure of the company / firm) :

10. Name, capacity and address of the signatory who has signed the Qualification Application Attested copy of authorization issued (either by power of attorney or as per articles of Partnership Deed / Memorandum of Association) in favour of the signatory to sign The Qualification Application price Tender / Agreement should be appended.

Dated Signature of Applicant with seal

Contractor

Managing Director,
T.N.H.W.C.S.LTD,CHENNAI

SCHEDULE "B"
FINANCIAL CAPABILITY

1. Name and address of the Applicant :
2. Income Tax permanent account No. C.I.H. No. :
3. TNGST / C.S.T/GST . Registration No. :
4. Annual turn over as per Income Tax returns filed for the :
TAX year past five years 2013-2014
2014-2015
2015-2016
2016-2017
2017-2018
5. Annual turn over as per audited statement of account :
Financial year duly certified by the Chartered
Accountant during the Preceeding Five years
(Attach attested copy of balance Sheets) 2013-2014
2014-2015
2015-2016
2016-2017
2017-2018
6. Financial Position :
 - i Cash in hand :
 - ii Cash in Bank / Banks. :
 - iii Current Assets. :
 - iv Current Liabilities :
 - v Working capital :
 - vi Net worth :
7. Outstanding value of works already committed and in
progress and time left for completion. (Details for
each work to be furnished separately)
8. Amount available in capital Account :
 - (i) Paid up share capital of (Partners or share holders)
 - (ii) Called up and subscribed share capital
 - (iii) Reserves under capital account.
 - (iv) Surplus under capital account.

9. Net profit before tax during the preceding five years. :

TAX year	2013-2014
	2014-2015
	2015-2016
	2016-2017
	2017-2018

Applicant's Financial arrangements.

- (a) Own resources.
- (b) Bank credits / Over Draft.
- (c) Other source (Specify the source)

Dated Signature of Applicant with seal

SCHEDULE “C”
DETAILS OF CONSTRUCTION EQUIPMENT, TOOLS & PLANTS,
VEHICLES THAT COULD BE DEPLOYED
EXCLUSIVELY FOR THIS WORK

NAME OF APPLICANT :

Sl. No.	Name of equipment / Tools & plants / Vehicles	Total requirement for this work	Equipments proposed to be taken on lease						
			Year of Purchase Make & Capacity	Present working condition	Year of Manufacture Make & Capacity	Present Working condition	Number	Year of Manufacture Make & Capacity	Present Working condition
1.	Concrete mixer with hopper	4 Nos							
2.	Vibrator	4 Nos							
3.	Dewatering Pumps	4 Nos							
4.	Lorry / Tipper	2 Nos							
5.	Steel centering materials to cover an area of	2000 Sq.m							
6.	Mechanical spray set of curing	3 Nos							
7.	Mechanical Hoist	1 No							
8.	Poclaim or JCB	1 No							
9.	Other tools & Plants available with the Applicant (details to be furnished)								

Note :- For the equipments currently under lease with the Applicant, Date of expiry of lease period shall be furnished.

Dated Signature of applicant with Seal.

Contractor

Managing Director,
T.N.H.W.C.S.LTD,CHENNAI

**SCHEDULE “D-1”
WORK EXPERIENCE
LIST OF CIVIL ENGINEERING CONSTRUCTION WORKS
COMPLETED IN THE PRECEEDING FIVE YEARS
NAME OF APPLICANT :**

Sl. No.	Name of work With location (Town / State)	Value of the work Rs.	Name of the Employer	Agreement number	Period of Completion Stipulated in the agreement	Time actually taken to complete the work	Reasons for delay (if any)	Type & nature of the work	Remarks
1	2	3	4	5	6	7	8	9	10
I.	Building works only								
II	Building & Works Including water supply and sanitary arrangements etc.								

Note :- a) Details of original construction works alone should be furnished.
Repairs / Improvements to existing structures should not be included.

Dated signature of the Applicant with seal.

Contractor

Managing Director,
T.N.H.W.C.S.LTD,CHENNAI

SCHEDULE “D-2”

A: DETAILS OF SIMILAR BUILDING WORKS COSTING MORE THAN RS.100.00 lakhs UNDER SINGLE AGREEMENT COMPLETED IN ANY ONE YEAR OF THE PRECEDING FIVE YEARS

NAME OF APPLICANT :

Sl. No.	Name of work	Location Village / Town / Taluk / District / State	Name and Designation of the employer / Owner	Value of work as per Agreement Rs.	Agreement Number	Stipulated Period of contract as per Agreement	Date of Commencement of the work	Date of Actual completion of work	Reasons for delay in completion (if any)	Actual Value of work Executed as per final Payment	Quality of work done
1	2	3	4	5	6	7	8	9	10	11	12
1. 2. 3											

Note :- a) Certificate issued by the Engineer- In – Charge (not below the rank of Executive Engineer / Project Engineer) of each of the work is to be appended.

Dated signature of the Applicant with seal.

Contractor

Managing Director,
T.N.H.W.C.S.LTD,CHENNAI

SCHEDULE “D-3”
DETAILS OF WORKS ALREADY COMMITTED BY THE
APPLICANT AND ARE IN PROGRESS

NAME OF APPLICANT :

Sl. No.	Name of work With Location	Name / Designation of the employer / or Owner	Agreement Number	Total Value of the work as per Agreement Rs.	Period of Completion Stipulated in the Agreement	Date of Commencement of work	Balance Period available for completing the remaining portion of work	Value of work so far completed. Rs.	Value of Balance item of work to be completed. RS.	Physical Progress or stage of work	Remarks
1	2	3	4	5	6	7	8	9	10	11	12
1.											
2.											
3.											
4.											
5.											
6.											

Note :- a) Certificate for each of the committed works in Progress issued by the Engineer- in – charge (not below the rank of Project Engineer) With all the above detail should be appended

Dated signature of the Applicant with seal.

Contractor

Managing Director,
T.N.H.W.C.S.LTD,CHENNAI

SCHEDULE “E”
INFORMATION REGARDING CURRENT LITIGATION / DEBARRING /
EXPELLING OF APPLICANT OR ABANDONMENT OF WORK BY THE
APPLICANT

1. (a) Is the Applicant currently involved in any Arbitration / litigation relating to the contract works. Yes / No
- (b) If Yes, Details thereon
2. (a) Has the Applicant or any of it’s constituent partners been Debarred / Expelled by any agency during the last Yes / No
- (b) If yes, Details thereon
3. (a) Has the Applicant or any of it’s constituent partners failed to complete, any contract work during the past “Five” years. Yes / No
- (b) If Yes, give details thereon.

Dated signature of Applicant with seal.

Note : If any information in this schedule is found to be incorrect or concealed the Qualification Application will be summarily rejected & price tender will not be opened.

SCHEDULE “F”**AFFIDAVIT**

(To be furnished in a Twenty Rupees Non-Judicial stamp paper duly certified by Notary Public)

1. I / We the undersigned solemnly declare that all the statements made in the documents, records etc., attached with this application are true and correct to the best of my knowledge.
2. I / We the undersigned do hereby certify that neither my / our firm / company nor any of it's constituent partners have abandoned any work /works of similar nature and magnitude in India , during the Last “Five” years.
3. I / We the undersigned do hereby certify that any of the contract awarded to me / us has not been terminated rescinded, due to breach of contractor on my / our part, during the last “Five” years.
4. I / We the undersigned authorise (s) and request (s) any bank / person / firm / Corporation / TNHWSC Ltd Departments to furnish pertinent information deemed necessary and requested by The managing Director TNHWSC Ltd ., Chennai to verify the statement made by me / us to assess my / our competence and general reputation.
5. I / We the undersigned, understand(s) that further qualifying information / clarification on the Statement made by me / us may be requested by the The Managing Director ,TNHWSC Ltd., Chennai and agree(s) to furnish such information / Clarification within “SEVEN” Days from the date of receipt of such request from The Managing Director TNHWCS Ltd Chennai.

Dated signature of Applicant with seal.

To be signed by the officer authorized by the Firm / company to sign on behalf of the Firm / company with company's seal.)

Note:-In case of sole proprietary concern,affidavit should be signed only by the sole proprietor.

(Title of the Officer)

(Title of the firm / company)

(Date)

The above named deponent has understood the contents well and solemnly and sincerely declared and affirmed by the deponent in my presence at

.....And signed before me on this day of

.....

(Seal)

(Signature of the Notary Public with seal)

Contractor

Managing Director,
T.N.H.W.C.S.LTD,CHENNAI

SCHEDULE "G"
UNDERTAKING

Under taking should be furnished in a Twenty Rupees Non- Judicial stamp paper with the Qualification Application and Certified by the Notary public.

I / We

The applicant do hereby undertake that I / we will abide by the terms and conditions if any modified by the TNHWSC Ltd in the contract conditions subsequent to submission of Qualification schedule / Price tender or subsequent to execution of the agreement.

Place :

Date : Signature of the applicant with Seal

The above named deponent has understood the contents well and solemnly and sincerely declared and affirmed by the deponent in my presence at

..... And signed before me

.....

On this day of

Place :

Date : Signature of the Notary public with Seal

Contractor

Managing Director,
T.N.H.W.C.S.LTD,CHENNAI

SCHEDULE “H”
Details of Technical personnel under regular employment of the applicant who can
be made available
exclusively for this work

Name of Applicant :

Sl. No	Designation	Name	Educational Qualification	Under regular employment with Applicant since.	Total span of experience	Salary being paid	Remarks
1	2	3	4	5	6	7	8
1.	Project Manager – B.E. Civil (with atleast 10 years experience.)– 1 No.						
2.	Site Engineers - B.E. ,Degree in Civil Engineering (with atleast 3 years experience) –2 Nos.						
(b)	Diploma in Civil Engineering (with atleast 3 years experience)– 3 Nos.						
3.	Number of skilled workmen available						
4.	Number of unskilled workmen available.						

Dated Signature of applicant with seal.

Contractor

Managing Director,
T.N.H.W.C.S.LTD,CHENNAI

TENDER DOCUMENT

Name of work : Construction of Marketing Complex at
Co-optex Regional office, Tirunelveli in
Tirunelveli District.

Total Number of pages in this tender
Document :

Number of items in schedule "A" :

Tender shall be submitting on or before
3.00 pm. on : **10.01.2019**

Tender Document sold to :

PARTICULARS TO BE FURNISHED BY THE TENDERER

- 1.Name of the tenderer and address : The Tamilnadu Handloom Weavers’
Co-operative Society Ltd.
Co-optex Head Office,
No:350, Pantheon Road, Egmore,
Chennai – 600 008
- 2.Name of work : Construction of Marketing Complex at
Co-optex Regional office, Tirunelveli
in Tirunelveli District.
- 3.Date of tender : **27.12.2018**
- 4.Total value of tender : Rs. 1,53,00,000/-
- 5.Details about E.M.D. enclosed for
this tender and its validity : Rs. 1,53,000/-
- 6.Registered class of the tenderer with
monetary limit and department in which
registered. Certified copy of the
registration should be attached. :
- 7.Recent work (details about name and
place of work, value of the work etc.,
should be furnished) :
- 8.Works under execution (details about
name and place of work value of the
work etc., should be furnished) :
- 9.Command of labour in brief :
- 10.Turnover of previous year (Particulars
for a period of three consecutive years
to be furnished) : 2014-2015
2015-2016
2016-2017

Contractor

Managing Director,
T.N.H.W.C.S.LTD,CHENNAI

11. Whether Income Tax clearance certificate is enclosed. If not when it will be produced? :

12 .(i) Sales Tax Registration Number
 (ii) PAN Number
 (iii) GST Registration Number
 (iv) Whether Sales Tax clearance certificate is enclosed? If not, when it will be produced :

13. In case of registered co-operative societies they should furnish name of the nominee with their credential details at the time of tender itself. They should also certify, that the nominee of the society is not a registered contractor in the :

14. TECHNICAL ASSISTANT DETAILS

1. Name :
 Qualification certificate
 Experience certificate :

2. Name :

Qualification certificate
 Experience certificate :

OR

1. Name :
 If retired Civil Engineer, Designation and date of retirement (copy to be enclosed) :

15. Any other details :

NOTE : *The consent letter from the Technical Assistant proposed to be employed should be obtained and enclosed with the tender.*

Declaration to be given by the Unemployed Engineer

1. Name :
2. Address :
3. Age :
4. Native place :
5. District :
6. Qualification :
7. Year of passing :
8. No. of years of employment
Name should be filled by Tender :
9. Name of the in which
registered as an unemployed Engineer :
10. Date of registration :
11. Class of contractor :
Monetary Limit
12. Previous experience in year
 - a) Irrigation b) Head works
 - c) Building d) Bridges
 - e) Others

(Details with regard to name of work, nature of work etc., may be furnished in a

Contracts	Name of work	Value of work	Period of work	Nomination of tender
(1)	(2)	(3)	(4)	(5)

Contractor

Managing Director,
T.N.H.W.C.S.LTD, CHENNAI

13. Annual turnover for first three years :2014-2015

2015-2016

2016-2017

14. Solvency / Immovable / Cash :

15. Tools and Plant owned :

16. Was there any default in fulfilling
terms of contract and result and
penal action :

17. Special remarks if any :

Station :

Date :

Signature and name of the

Unemployed Engineer

Tamil Nadu Handloom Weavers Co-operative Society Ltd.,

- Name of work : Construction of Marketing Complex at
Co-optex Regional office premises Tirunelveli.
- Last Date for receipt of tender : 10.01.2019 upto 3.00 pm
- Date and time of opening : 10.01.2019 at 4.00 pm
- E.M.D. to be remitted : Rs.1,53,000 /-
- Mode of E.M.D. to remitted : Demand draft of the Nationalized and Scheduled
banks drawn in favour of TNHWCS Ltd. payable at
Chennai

Note :

1. *The tender and E.M.D. should be enclosed in separate covers, both the covers should then be submitted In a common sealed cover. All the three covers should be sealed. Tenders not submitted In sealed cover will be summarily rejected.*
2. *The rate In words and figures for each item of schedule should be furnished by the tenderer without fall In appropriate columns. Corrections scribbling overwriting and erasing (should be avoided as far as possible) should be attested by the contractor.*
3. *The total value of each Item of work should be worked out and entered in the amount column. Proper care must be taken in working out the value of each item of work taking Into account the unit for which the rate is quoted and the quantity of work to be done under the Item.*
4. *The total of each page should be noted at the end of each page and carried over to next page. The grand total value of the tender should be worked out and furnished at **the** end, both In. words and figures.*

CONTRACTOR

THE MANAGING DIRECTOR

FOR SPECIAL ATTENTION OF THE TENDERER

1. Proof of registration in Public work Department /Government Department /Any other organization/Firm Co-operative Industries as a contractor shall be attached with the tender.
2. Current Income Tax clearance certificate shall be enclosed with the tender.

Contractor

Managing Director,
T.N.H.W.C.S.LTD,CHENNAI

3. Sales Tax Registration Number should be furnished and Sales Tax clearance Certificate should also be produced before finalisation of contract.
4. GST Registration Number should be furnished.
5. E.M.D. will be accepted in the shape of Demand Draft of the Nationalized and Scheduled banks drawn in the name of TNHWCS Ltd., There is no Interest payable for EMD.
6. Tenders filled in the Prescribed forms should be reach. The Tamil Nadu Handloom Weaver's Co-operative Society on or **before 10.01.2019 on 3.00 PM** in sealed over super scribed with name of the work Tender No.

Rates must be Quoted for completed work at site.(Including Sales cost , Taxes any other charges etc.)All charges like sales Tax, Work Contract charges ,GST Registration and ESI Charges etc., work to be borne by the contractor and Co-optex will not entertain claim what so over in this respect.

7. The following particulars shall also be furnished by the contractor along with the tender.
 - a) List of details of works executed by the contractor with their value.
 - b) A list of details of work under execution by the contractor with their values.
 - c) Annual turnover of the last one year (necessary certificate to the effect issued by the respective bank and Income Tax certificate shall be attached.
8. The lowest tenderer when informed that his tender is under consideration shall have to furnish PERT CHART in the proper form with in a week from the date of receipt of letter calling for PERT CHART. The PERT CHART should confirm to the department time schedule for the completion of the work furnished in the tender notice. If the PERT CHART is not received within a week from the date of communication, his tender will not be considered.
9. The tender documents will be issued to the contractors registered in PWD /Government Department /Organization /Firm /Co-operative Industries in the appropriate class.

SPECIAL INSTRUCTION TO THE TENDERERS

1. The Tenderer should carefully go through the tender schedule and quote their rates for all items.
2. The rates should be filled in neatly in figures and in words and taking into account the metric units specified in the tender, scribbling, over writings and erasing should be avoided as far as possible.

Contractor

Managing Director,
T.N.H.W.C.S.LTD,CHENNAI

3. The amount of each item of work should be worked out. Proper care must be taken in working out the amount of each item of work taking into account the unit for which the rate is quoted and the quantity of work to be done under the item.
4. The total for each page should be arrived at end, carried out to every page and the grand total value of work should be worked out and shown at the end.
5. The tender should be submitted along with a covering letter giving full details, as called for in the tender notice together with the copy of letter registering them into the appropriate class.
6. In case the tenderers who are eligible for concessional Earnest Money Deposit and accordingly they should furnish the reference No. and date in which the concession was granted to them A copy of the aforesaid reference may be enclosed along with the tender for ready reference.
7. Income tax clearance certificate for the current year should be submitted along with the tender or the tender in which the Income Tax clearance certificate for the current year was submitted to this office should be specified.
8. Details of previous work done by the Tenderers covering the cost of the work, the agreement, No. date, department in which the work was carried out, etc., should be furnished so as to assess the previous experience of the tenderers. Year wise details should be furnished so as to see that these tenderers have minimum experience of major building.
9. List of various machinery and other equipments at the tenderers disposal for use in the execution of the work, should be furnished.
10. The TENDER form should be filled in while submitted the tender. The tenders submitted without filling up the tender form are liable to be rejected.
11. The tender must be submitted in a sealed foolscaps cover duly signing all the conditions.

APPENDIX -1
TENDER NOTICE

1. Tenders will be received by the Managing Director, Co – optex Ltd, Head office, Egmore Chennai. 600 008 up to **3.00 PM on 10.01.2019** for the construction of Marketing complex in **Co-optex regional office premises at Tirunelveli.**

The tenders should be in the prescribed form obtainable from the Managing Director, Co -optex Ltd, Head office, Egmore Chennai. 600 008. The tenders will be opened by the Tender Committee **at 4.00 P.M. on the same day** at the place aforementioned.

The tenderers or their agents are expected to be present at the time of opening of tenders. The tender receiving officer will on opening each tender prepare a statement of the attested and unattested corrections therein and hand it over to the tenderer concerned and initial all corrections in the presence of the tenderers. If any of the tenderers or their agents finds it inconvenient to be present at the time, then in such a case, the tender receiving officer will on opening the tender of the absentee tenderer, make out a statement of the unattested corrections and communicate it to him. The absentee tenderer shall then accept the statement of the corrections without any question whatsoever.

2. Tenders must be submitted in sealed covers and subscribed with name of the work and should be addressed to the Managing Director, Co – optex Ltd, Head office, No:350, Pantheon Road, Egmore Chennai. 600 008 the name of the tenderer and name of the work being noted on the Cover. If the tender is made by an individual, it shall be signed with his full name and his address shall be given. If it is made by firm it shall be signed with the co-partnership, name by a member of the firm who shall also sign his name and the name and address of each member of the firm shall be given. If the tender is made by a corporation it shall be signed by a duly authorised officer who shall produce with his tender, satisfactory evidence of his authorisation. Such tendering corporation may be required, before the contract is executed, to furnish evidence of its corporate existence.
2. Each tenderer must also send a certificate of Income Tax Verification from the appropriate Income Tax authority in the form prescribed therefor. The certificate will be valid for one year from the date of issue for all tenders submitted during the period.

In the case of proprietary or partner firm it will be necessary to produce the certificate aforementioned for the proprietor or proprietors and for each of the partners as the case may be.

If the tenderer is a registered PWD /Government Department /Organization /Firm /Co-operative Industries Contractor and if a certificate for the current year had already been produced by him during the calender year in which the tender is made, it will be sufficient, if particulars regarding the previous occasions on which the said certificate was produced, are given.

All tenders received without a certificate aforementioned will be summarily rejected.

4. Each tender must pay an Earnest Money, Deposit a sum of **Rs.1,53,000/-** Demand Draft at Nationalized Bank in favour of TNHWCS Ltd.

This E.M.D. will be refunded to the unsuccessful tenderer on application after intimation is sent of rejection of the tender or at the expiration of three months from the date of tender whichever is earlier. The refund will be authorised by the Managing Director, Co - optex Ltd, Head office, Egmore Chennai. 600 008.

The EMD will not carry any interest. It will be dealt with as provided in the tender.

5. The tender will remain valid for a period of 90 days from the last date of receipt of tender. The validity period can be extended further if the contractor gives his consent in writing specifying the period of extension.
- i) The tenderer whose tender is under consideration, shall attend the TNHWCS Ltd office before the end of the period specified by written intimation to him. In case, the tenderer fails to attend the office before the end of the specified period, his tender will not be considered. He shall forthwith upon intimation being given to him of acceptance of his tender, by the officer duly authorised in his behalf under article 299 (1) of the constitution hereinafter called "The accepting authority," make security deposit of 2% of the value of contract by taking into account of the amount of EMD already deposited with the tender it would be sufficient to pay the balance amount to make up the 2% of the value of contract for the purpose of Security deposit. However, the security deposit of one percent of the estimate cost of work can be deposited as one time deposit by the contractor. The security deposit together with earned Money Deposit and the amount withheld according to clause 64-1 of General conditions of Contract shall be retained as Security for the fulfillment of contract. If a cash Security Deposit is made by the contractor, he shall follow the procedure laid down in the proceeding paragraph for payment of Earnest Money Deposit and such deposit shall not bear interest
- ii) On receipt of written communication of acceptance of tender, if the tenderer fails to pay the requisite security deposit within the period specified in the written communication or backs out from the tender or withdraws his tender, the Earnest Money Deposit shall be forfeited to the TNHWCS Ltd.

If the contractor fails to carryout the contract, after paying requisite deposits, then he will be liable for the excess expenditure if any incurred to complete the work as contemplated in the General Conditions of Contract.

- (iv) It shall be expressly understood by the tenderer that on receipt of written communication of acceptance of tender by the tenderer there emerges a valid contract between the behalf of Managing Director and the tenderer, for execution of the work without any separate written agreement. For this purpose the tender documents ie., tender notice, tender offered by the contractor, General Conditions of Contract, special conditions to the contract, correspondence, written communication of acceptance of tender etc., shall constitute a valid contract and that will be foundation of the rights of the both the parties to the contract.

Provided that it shall be open to the accepting authority to insist on execution of any written agreement by the tenderer, if administratively considered necessary *or* expedient,.

6. The tenderer shall examine closely the Tamilnadu Building practice and also the General Conditions of Contract contained therein, and sign the Co-optex Head Office ,Chennai al office copy of the Tamil Nadu Bldg., Practice and its addenda volume in token of such study before submitting his tender unit rates, which shall be for finished work in situ. He shall also carefully study the drawing and addl. specifications and all the documents connected with the contract. The Tamilnadu Bldg., practice and other connected documents with the contract such as specifications, plans, descriptive specifications sheet regarding materials etc. can be seen at any time between 11.00 a.m. and 5.00 p.m. on office, days in the office of the Managing Director, Co – optex Ltd, Head office, Egmore Chennai. 600 008.

A copy of the set of contract documents can also be had on payment of Rs.15000/- for each set and GST 18%

7. The tenderers attention is directed to the requirement for materials under the clause "Materials and workmanship" in the General Conditions of Contract. Materials confirming to the ISI. Standards shall be used on the work, and the tenderer shall quote his rates accordingly.
8. Every tenderer is expected before quoting his rates, to inspect the site of the proposed work'. He should also inspect the quarries and satisfy himself about the quality and availability of materials. The name of quarries and kiln etc. where from certain materials are to be obtained will be given in the descriptive specification

sheet. The best class of materials to be obtained from the quarries or other source defined shall be used on the work. In every case the materials must comply with the relevant standard specification. Samples of materials as called for in the standard specification or in the tender notice or as required by the Departmental Engineer shall be submitted for Departmental Engineer approval before the supply to site of work is begun. If the contractor after examination of the source of materials defined in the descriptive specification sheet is of the opinion that materials complying with the standard or other specification of the contract cannot be obtained in quality or sufficient quantity, from the source defined in the descriptive specification sheet, he shall so state in his tender and state where from he intends to obtain materials, subject to the approval of the Departmental Engineer.

The TNHWCS Ltd will not, however, after acceptance of contract rate pay any extra charges for lead or for any other reasons, in case the contractor is found later on to have misjudged the materials available. Attention of the contractor is directed to the "General Conditions of Contract" regarding payment of seignior age tolls etc.

9. The tenderer's particular attention is drawn to the sections and clause in the General Conditions of Contract dealing with.
 1. Test, Inspection and rejection of defective materials and work.
 2. Carriage
 3. Construction plant
 4. Water and Lighting
 5. Cleaning up during progress and for delivery
 6. Accidents
 7. Delays
 8. Particulars of payment.
 9. The contractor should closely peruse all the specification clauses which govern the rates which he is tendering.
10. A schedule of quantities accompanies this tender notice. It shall be definitely understood that the TNHWCS Ltd. does not accept any responsibility for the correctness or completeness of this schedule and that this schedule is liable to alterations by omissions deduction or additions at the discretion of the the Managing Director, Co – optex Ltd, Head office, Egmore Chennai. 600 008 as set forth in the conditions of contract. The tenderer will, however base his lump sum tender on this schedule of quantities. He should quote specific rates for each item in the schedule

and the rates should be in rupees and in sums of five paise. The rates should be written both in words and figures and the units words. The tenderer should also show the totals of each item and the grand total of the whole contract and quote in the tender a lumpsum of which he will undertake to do the whole work subject to the conditions of contract such lumpsum agreeing with the total amount of Schedule A. The schedule accompanying the lumpsum tender shall be written legibly and free from erasures, over writings, or conversion of figures. Corrections, where unavoidable should be made by crossing out, initialing dating and rewriting.

11. Tenderers offering a percentage deduction from or increase on the estimate amount except in the case of tender for maintenance and repair works called for specifically under percentage rate tender system and those not submitted in proper form or in due time will be rejected.
12. The tenderer should workout his own rates, without reference being made to the in Public Work Department schedule of rates or the estimate. However in case of tenders called for under % rate tender system the tenderer should workout his own rate but quote his percentage rate above or below the total estimated cost of the work of the department indicated in the tender schedule.
13. The price at which and the sources from which certain particular materials shall be obtained by the contractor are given at the end of the schedule accompanying the tender form. Tenderer must accept the materials at these prices and shall quote their price for finished works accordingly. Notwithstanding any subsequent change in the market value for these materials, the charges to the contractor will remain as originally entered in the written contract. No cent age or incidental charges will be borne by TNHWCS. in connection with this supply.
14. The attention of the tenderer is directed to the contract requirements as to the time of beginning of work the rate of progress and the dates for the completion of the whole work and several parts. The following rate of progress and proportionate value of works done from time to time as will be indicated by the Departmental Engineer.certificates of the value of work done will be required. Date of commencement of the programme will be the date on which the site (or Premises) is handed over to the contractor.

Total percentage of work to be
completed based on contract lumpsum
amount

Period after date of commencement

1 st Month5%
2 nd Month5%
3 rd Month10%
4 th Month10%
5 th Month10%
6 th Month10%
7 th Month10%
8 th Month10%
9 th Month5%
10 th Month5%
11 th Month10%
12 th Month10%
(Total 12 th Months)100%

Note : The period to be entered in col. 1 for the purpose of following the rate of progress may be fixed by The Managing Director.

15. No part of the contract shall be sub-let without written permission of the Managing Director nor shall transfer be made by power of attorney, authorising others to receive payment on the contractor's behalf.
16. If further necessary information is required the Managing Director of the TNHWCS Ltd will furnish such but it must be clearly understood that tenders must be received in order and according to instructions.
17. The Managing Director or other sanctioning authority reserves the right to reject any tender or all the tenders .
18. The tenderers who are themselves not professionally qualified shall undertake to employ Qualified technical men at their cost to look after the work. The tenderers should state in clear terms whether they are professionally qualified or whether they undertake to employ technical men required by the department specified in the schedule below for the work. In case the selected tenderer is professionally qualified or has undertaken to employ technical men under him, he should see that one of the technically qualified men is always at the site of the work during working hours personally checking all items of works and paying extra attention to such works as may demand special attention (e.g.) reinforced concrete works etc.

(The norms for the employment of technical Assistant and penalty for non-employment of such technical Assistant etc, is furnished in the format below)

Contractor

Managing Director,
T.N.H.W.C.S.LTD,CHENNAI

EMPLOYMENT OF TECHNICAL ASSISTANTS

NOTE :- 1

Employment of Technical Personnel

- | | |
|-------------------------------|---|
| 1. From one to Rs. 5.00 Lakhs | 1) One Diploma Holder in Civil Engineering
(or)
2) Not less than one retired Junior Engineer |
| 2. From Rs. 5 to 10 lakhs | 1) One B.E., (Civil)
(or)
2) Equivalent Degree holder
(or)
3) Not less than one retired Sub Officer AEE / ADE
(or)
4) One Diploma Holder with three experience. |
| 3. From Rs. 10 to 25 lahs | 1) One B.E., (Civil) with 3 years plus ONE DIPLOMA Holder in Civil Engg.
(or)
2) Equivalent Degree holder with 3 years experience plus one Diploma holder in Civil Engg.
(or)
3) Not less than one retired Sub-.....al Officer plus one Diploma holder in Civil Engg.
(or)
4) Two diploma holder in Civli Engg. with 3 and 5 years experience respectively. |
| 4. From Rs. 25 to 50 lakhs | 1) One B.E., Civil with 3 years experience plus two diploma holders in Civil Engg.
(or)
2) One B.E., (Civil) with 3 years experience |

Contractor

Managing Director,
T.N.H.W.C.S.LTD,CHENNAI

plus two retired Junior Engineers.

(or)

- 3) Equivalent degree holder with 3 years experience plus two Diploma holders in Civil Engg. or Two retired Junior Engineers

(or)

- 4) One retired Subal Officer (AEE or ADE) Plus two diploma holders in Civil Engg. or one retired SDO (AEE or ADE) Plus two retired Junior Engineers

5. Above Rs. 50 Lacs

- 1) To be examined in individual cases depending upon the nature of work and the technical skill involved and defined in the tender notice regarding the No. of qualified technical personnel to be employed by the contractor

2. A penalty of Rs. 2,000/- PM for diploma holder and Rs. 5,000/- PM for Degree Holder be levied in case of default on the part of contractors in the norms mentioned above.
3. The employment of Technical Assistant should be based only on the value of contract. Engineers with Mechanical Engineering qualification and retired from Civil Engineering Departments are also suitable to supervise the Civil Engineering works because of their experience in Civil Engineering field.
4. The tenderer who himself is not professionally qualified should undertake to employ qualified technical men at his cost to look after the work. The tenderer should state in clear terms whether he undertakes to employ technical men required by the Department specified in the Schedule below for the work. In case the selected tenderer is professionally qualified or has undertaken to employ. Technical men under him he should see that one of the technically qualified men is always at the site of work during working hours, personally checking all items of works and paying extra attention to such works as may demand special attention eg. reinforced cement concrete works etc.
5. It will not be incumbent on the part of the Contractor to employ Technical Assistants when the work is kept in abeyance due to valid reasons and during such period in the opinion of the Departmental Engineer the employment of Technical Assistant is not

Contractor

Managing Director,
T.N.H.W.C.S.LTD,CHENNAI

required for the due fulfillment of the Contract.

19. Tenderer submitting a tender which the tender accepting authority considers excessive and/ or indicative of the insufficient knowledge of current prices or definite attempt at profiteering will render himself liable to be debarred permanently from tendering or for such period as the tender accepting authority may decide. The tender rates should be based on the controlled price for materials - price permissible for the tenderer to charge a private purchaser under the provision of clauses 8 of hoarding and profiting prevention ordinance 1943 as amended from time to time and on similar principles in regard to labour and supervision in the construction.

20. The contractor should offer employment to ex-toddy tappers as far as possible.

Note: *This paragraph should be scored out if the cost of work involved is less than Rs, 10, 000/-*

21. The contractor shall comply with the provisions of the Apprentices Act 1961 and the rules and orders issued there under from time to time. If he fails to do so, his failure will be a breach of the contract and the competent authority, may at his discretion, cancel the contract or invoke any of the penalties for the breach of contract provided in the conditions of agreement. The contractor shall also be liable for any pecuniary liability arising on account of any violation by him of the provisions of the Act. Contractor shall, during the currency of the contract, ensure engagement of the apprentices in the categories mentioned below who may be assigned to him by the Director of Employment and Training/State Apprenticeship Adviser, Tamil Nadu. The contractor shall train them as required under the Apprentices Act 1961, and the rules made there under and shall be responsible for all obligations of the employer under said Act including the liability to make payments to the apprentices as required under the said Act.

Value of contract		Category	No. to be appointed
Rs. 1.00 lakh and upto Rs. 3.00 lakhs	1.	Building	1
	2.	Constructor Brick	
Above Rs. 3.00 lakhs and upto 10.00 lakhs	1.	Building Constructor	1
	2.	Brick layer Diploma	
	3.	holder in Civil Engineering	1
Above Rs. 10 lakhs and upto 50.00 lakhs	1.	Building Constructor	1
	2.	Brick layer B.E., (Civil) or equivalent	1
	3.	degree holder	1

Contractor

Managing Director,
T.N.H.W.C.S.LTD, CHENNAI

"Unless the contractor has been exempted from engagement of apprentices by the Director of Employment and Training/State Apprenticeship Adviser, a certificate to the effect that "That contractor had discharged his obligation under the said Act, satisfactorily should be obtained from the Director of employment and Training/State Apprenticeship Adviser" and the same should be produced by the Contractor for final payment in the settlement of contract.

22. In the case of contracts for construction of buildings either permanent or semi permanent buildings, a sum equivalent to 2 1/2% of the value of work done will be retained with the TNHWCS Ltd. for a period of one year reckoned from the date of completion of the work in order to enable the departmental officers to watch the effect of all seasons on the work done by the contractor. The amount so retained with the TNHWCS Ltd. will be refunded only on the expiry of one year period referred to above and on execution of Indemnity bond by the contractor for a further period of four years. The contractor shall be liable to set right all the defects arising out of his faulty execution or sub standard work noticed during the above five years period at his cost.

***THE MANAGING DIRECTOR
CO-OPTEX LTD, HEAD OFFICE, NO:350,
Pantheon Road Egmore, Chennai 600 008.***

II. TENDER

To

THE MANAGING DIRECTOR
Co-optex Head Office,
NO:350, Pantheon Road Egmore,
Chennai 600 008.

Sir,

1. I/We do hereby tender and if this tender be accepted undertake to execute the following work viz, as shown in the drawings and described in the specification deposited in the office of the Tamil Nadu Handloom Weavers Co-operative Society Ltd., Head Office Chennai with such variations by way of alterations or additions to and omission from the said works and method of payment as are provided for in the conditions of contract for the sum of Rupees (in figures and words)

or such other sum as may be arrived at under the clause of the General Conditions of Contract relating to "Payment on lumpsum basis or by final measurements at unit prices"
2. I/We have also completed the priced list or items in schedule "A" annexed (in words and figures) for which I/We agree to execute the work and receive payment on measured quantities as per the General Conditions of Contract.
3. I/We do hereby distinctly and expressly declare and acknowledge that before the submission of my or our tender, I/We have carefully followed the instruction in the tender notice and have read the Tamilnadu Building Practice and the General Conditions of Contract there-in and the Tamilnadu Building Practice addenda volume, and that I/We have made such examination of the contract documents and of the plans, specifications, quantities and of the location, where the said work is to be done and such investigation of the work required to be done and in regard to the materials required to be furnished as to enable to thoroughly understand the intention of the same and requirement, covenants, stipulations and restrictions contained in the contract and in the said plans and specification, and distinctly agree that I/We will not hereafter make any claim or demand upon the TNHWCS Ltd. based upon or arising out of any alleged misunderstanding or misconception or mistake on my/our part of the said requirements covenants stipulations restrictions and conditions.

Contractor

Managing Director,
T.N.H.W.C.S.LTD,CHENNAI

4. I/We enclose an income tax verification certificate.

I/We being a registered PWD contractor have already produced an Income Tax verification certificate during the current calendar year in respect of (here particulars of the previous occasions in which the certificate was produced should be given) The legal address of the contractors for service of all letters and notices will be as follows.

5. (i) (a) I/We enclose herewith a chalan for the payment of the sum of Rs.1,53,000/- (Rupees One Lakh Fifty Three thousand only) as Earnest Money not to bear interest.

5. (i) (b) I/ We have paid Rs(Rupees.....,.....
..... as against the E.M.D. of Rs.,
(Rupees.....)only.
Since I am/We are eligible to pay the EMD, at concessional rates.

5. (i) (c) in lieu of a cash

I/Wehave enclosed a.....
bearing No Date.....
issued by
for a value of Rs.....
drawn / enclosed /pledged in favour of the
T.N.H.W.C.S .Ltd., Chennai

5. (i)(d) I am / We are
and hence exempted from payment of E.M.D.

6. If my/our tender is not accepted this sum shall be returned to me/us on my/our applications when intimation is sent to me/us of rejection or at the expiration of three months from the date of this tender whichever is earlier. If tender is accepted, the Earnest Money shall be retained by the TNHWCS as security for the due fulfillment of contract. If upon intimations being given to me/us by the authority authorized by the Governor under article 299 (1) of the constitution (hereinafter called the accepting authority) of acceptance of tender (I/We) fail to make the additional security Deposit, then I/We agree to the forfeiture of Earnest Money Deposit. Any notice required to be served on me or us hereunder shall be sufficiently served on me or us if delivered to me or us personally or forwarded to me or us by post (Registered or ordinary) or left at my or our address given herein. Such notice shall, if sent by post be deemed to have been served on me or us at the time when in due course of post it would be delivered at the address to which it is

sent.

7. I/We fully understand that on receipt of communication of acceptance of tender from the accepting authority, there emerges a valid contract between me/us and the Governor of Tamilnadu and the tender documents ie. Tender notice tender with schedules General Conditions of Contract and special conditions of the tender negotiation letters, communications of acceptance of tenders, shall constitute a contract for this purpose and be the foundation of rights of both the parties provided that it shall be open to accepting authority to insist on execution of any written Agreement by the tenderer, if administratively considered necessary or expedient.
8. I/We have also signed the copy of Tamilnadu Building practice and addenda volume, thereto maintained in the .Co-optex Head Office in acknowledgement of being bound by all conditions of the clauses of the General Conditions of Contract and all specifications for item of works described by a specification number in Schedule A.
9. In consideration of the payment of Rupees or such of the sum as may be arrived at under the clause of the General conditions of contract, relating to payment of lumpsum basis or by final measurement at unit prices I/We agree subject to said conditions to execute and complete the works shown upon the said drawing serially from number I to inclusive (Schedule - B) and described in the specifications (Schedule - C) and to the extent of probable quantities shown in (Schedule - A) with such variations by way of alterations additions to or deductions from the said work and method of payment therefor as are provided for in the said conditions.
- 10.(i) The term "Department Engineer" in the said condition shall mean the Co-optex officer in charge of the Chennai having jurisdiction for the time being over the work who shall be competent to exercise all the powers and privileges reserved herein in favour of the Govt. with the previous sanction of or subject to ratification by the competent authorities in case where such sanction or ratification may be necessary and who has been duly authorised under articles 299 (1) of the constitution.

11. I/We agree that the time shall be considered as the essence of the contract and I/We hereby agree to commence the work as soon as this contract is accepted by the competent authority as defined by the Tamil Nadu Building prating code and the site (or premises) is handed over to me/us as provided for in the said conditions and agree to complete the work within **Twelve (12)** months from the date of such handing over of the site (or premises) and to show progress as defined in the tabular statement "rate of progress" subject nevertheless to the provisions for extension of time contained in clause 56 of the General Conditions of Contract appended to the Tamil Nadu Building Practice
12. I/We agree that upon the terms and conditions of this contract being fulfilled and performed to the satisfaction of The Managing Director, the security deposited by me / us as herein before recited or such portions thereof as I/We may be entitled to under the said conditions be paid back to me/us as provided in clause 64 of the General conditions of Contract.
13. I am/We are professionally qualified and my/our qualification are as follows.

Name	Qualification	Experinece

I/We in pursuance of clause 18 of tender notice, undertake to employ the following technical staff for supervising the work and will see that one of them is always at site during working hours personally checking all items of works and paying extra attention to such works ,, as may require special attention (eg) reinforced cement concrete.

	Name of technical staff proposed to be employed (1)	Qualification (2)	Experience (3)
1.			
2.			
3.			

Contractor

Managing Director,
T.N.H.W.C.S.LTD,CHENNAI

14. I/we agree that the arbitrator for fulfilling the duties set forth in the arbitration clause of the General Conditions of Contract shall be :

***The managing director ,
Co-optex Ltd,Head office,
No:350, Pantheon Road Egmore,
chennai 600 008.***

3. In case, the value of claim does not exceed Rs.50,000 /-

4. I/we agree that in case of the value of claim is over Rs.50,000/- and the above,the remedy will be through the competent of civil court only.

Signature of the Contractor with Date

15. On behalf of the TNHWCS Ltd and as duly authorised by the Managing Director under article 299 (1) of the constitution the above tender for a value of Rs only is accepted on this day of of 2018

Signature and Designation

*Signature of Contractor in full
and address with name in block letters*

SCHEDULE - A

(Schedule of Rates and Approximate Quantities)

- A. The quantities here given are those upon which the lump sum tender cost of the work is based but they are subject to alterations, omissions, deductions or additions as provided for in the conditions of this contract and do not necessarily show the actual quantities of work to be done. The unit rates noted below are those governing payment of extras or deductions for omissions according to the conditions of the contract as set forth in the General Conditions of Contract in Tamilnadu Building Practice and other conditions specifications of this contract.
- B. It is to be expressly understood that the measured work is to be taken nett (Not with standing any custom or practice to the contrary) according to the actual quantities when in place and finished according to the drawings or as may be ordered from time to time by the Departmental Engineer and the cost calculated by measurement or weight at the respective prices without any additional charge for any necessary and contingent works connected therewith. The rates quoted are for works in situ complete in every respect.

Item No	Probable Quantities	Class and Description work	T.N.E.B.P No or other special specification no if any	Rate World Figure	Unit Words	Amt figure
VIDE SHEETS ATTACHED SEPARATELY						

SCHEDULE –B

LIST OF DRAWINGS

VIDE SHEETS ATTACHED SEPARATELY

Note: All drawings to be signed by the contractors as well as the officer entering into the contract.

SCHEDULE -C

List of specifications for the various items of works supplementing those described in Schedule A by standard specification numbers.

1. The contractor shall employ the following technical staff for supervising the work and shall see that one of them always at site during working hours personally checking all items of work and paying extra attention to such works as may demand special attentions eg. reinforced cement concrete works etc.

Name of the members of the technical staff to be employed	Qualification & Experience

Note 1 : In case the contractor Is himself professionally qualified the above specification should be suitably altered and In case In which the contractor selected has not given In undertaking to employ qualified men it should be scored out.

2. A penalty of Rs. 2,000/- per month for Diploma Holder and Rs. 5,000/- p.m. for Degree holder be levied in case of default on the part of the contractors as per norms fixed by the TNHWCS Ltd., for employment of Technical Assistant.
3. The employment of Technical Assistant should be based only on the value of contract Engineers with Mechanical Engineering qualification and retired from Civil Engineering Departments are also suitable to supervise the civil Engineering works because of their experience in Civil Engineering Field.
4. In case of the contractor who is professionally qualified is not in a position to remain always at the site of the work during hours personally checking all items of the work and paying extra attention to work as may demand special attention (eg) R.C.C. work etc. he should employ technically qualified men as prescribed for the works.
5. A movement register should be maintained for Technical Assistants employed by the Contractor or for the technically qualified Contractor. The Technical Assistants or Technically qualified contractors should note the arrival and the departure timings every day along with-their initials. Such register should be produced during inspection of the Inspecting Officer.

Contractor

Managing Director,
T.N.H.W.C.S.LTD,CHENNAI

6. It will not be incumbent on the part of the contractor to employ Technical Assistants when the work is kept in abeyance due to valid reasons and if during such period in the opinion of the Departmental Engineer, the employment of Technical Assistants is not required for the due fulfillment of the contract.
7.
 - a. Child Labour (Prohibition & Regulation) Act 1986: The Act prohibits employment of children below 14 years of age in certain occupations and processes and provides for regulations of employment of children in all other occupations and processes. Employment of Child Labour is prohibited in Building and Construction Industry.
 - b. The works contract assigned to the Contractors shall be cancelled if they engaged Child Labour in executing works and such contractors should be blacklisted for three years.

Special Condition of Contract

1. Safety measures to be observed for the prevention of Children being trapped and falling in to bore well / tube wells or abandoned well.

General Guidelines issued by Supreme Court of India

- (i) The owner of the land/premises, before taking any steps for constructing bore well/tube well must inform in writing at least 15 days in advance to the concerned authorities in the area, i.e., District Collector/ District Magistrate/ Sarpanch of the Gram Panchayat/ concerned officers of the Department of Ground Water/Public Health/ Municipal Corporation, as the case may be, about the construction of bore well/ tube well.
- (ii) Registration of all the drilling agencies, viz., Government / Semi Government / Private etc., should be mandatory with the district administration.
- (iii) Erection of signboard at the time of construction near the well with the following details:-
 - (a) Complete address of the drilling agency at the time of construction/ rehabilitation of well.
 - (b) Complete address of the user agency/ owner of the well.
- (iv) Erection of barbed wire fencing or any other suitable barrier around the well during construction.

- (v) Construction of cement/ concrete platform measuring 0.50 x 0.50 x 0.60 meter (0.30 meter above ground level and 0.30 meter below ground level) around the well casing.
- (vi) Capping of well assembly by welding steel plate or by providing a strong cap to be fixed to the casing pipe with bolts & nuts.
- (vii) In case of pump repair, the tube well should not be left uncovered.
- (viii) Filling of mud pits and channels after completion of works.
- (ix) Filling up abandoned bore wells by clay/sand/ boulders / pebbles /drill cuttings etc., from bottom to ground level.
- (x) On completion of the drilling operations at a particular location, the ground conditions are to be restored as before the start of drilling.
- (xi) If a bore well / tube well is 'Abandoned' at any stage, a certificate from the concerned department of Ground Water/ Public health / Municipal Corporation / Private contractor etc., must be obtained by the aforesaid agencies that the 'Abandoned' bore wells/ tube well is properly filled upto the ground level. Random inspection of the abandoned wells is also to be done by the Ground Water/Public Health/ Municipal Corporation of the concerned agency/ department. Information on all such data on the above are to be maintained in the District Collector/ Block Development Office of the State.

SCHEDULE –C**Special Conditions**

1. Tenders with tampered seals will not be accepted.
2. Tenders in which the rates are not written in words will generally be rejected. In case of any discrepancy while expressing rates in words, the rate whichever is advantageous to TNHWCS Ltd. will only be taken into account. Tenders containing overwriting, corrections which are not attested by the tenderers will be liable for rejection.
3. The contractor should satisfy himself about the availability of the various materials at the quarries specified in the tender schedule for the work before tendering. In case, the contractor feels any difficulty in procuring the material from the stipulated quarries he should make a special mention of the fact with details of the quarry / Quarries from which he proposes to bring the required materials for the work in the covering letter to accompany his tender. Any claim for payment of extra cost on account of increase in the lead for materials at the later stage will not be accepted.
4. In case it is found by the Departmental Officers that the contractor has brought any of the required materials from a quarry with lesser lead than that is specified. in the schedule, proportionate deductions will be made from the contractors rate of payment for the finished work for the respective item / items of work.
5. A deduction of 2% will be made towards income Tax and sales Tax in every payment made to the contractor.
6. Percentage Tender Conditions :
On evaluation of Tender if it is found that if the overall quoted amount of the, Tender is less than 5 to 15% of the value put to Tender, the contractor shall pay an additional security at 2% of the estimated value. If the tender discount exceeds 15% to 20% the contractor shall pay an additional, Security deposit of 50% of the difference between the quoted amount and estimate amount Failure to furnish the Additional Security Deposit within 15 days from the date of receipt of Acceptance order and execute the Agreement shall entail cancellation of award of contract and forfeiture of E.M.D. furnished,"
7. An additional Security deposit of 1 % of the value of the contract in one of the forms prescribed above will be remitted by the successful tenderer, if called for by the tender finalising authority.

8. A movement register should be opened and maintained for Technical Assistants employed by the Contractor or for the Technically qualified contractor. The Technical Assistant or Technically qualified Contractor should note the arrival and the departure timings every day along with their initials. Such Register should be produced during inspection of the Inspecting Officers.
9. Without prejudice to the generality of the above clause the contractor shall during the currency of the contract, when called upon by the Engineer-in-charge engage and also ensure engagement by the Sub Contractors and others employed by the contractor in connection with the work such number of apprentices in the category mentioned, below and for such period, as may be required by the Engineer-in-charge. The Contractor shall train them as required under the Apprentices Act 1961 and the rules made there under and shall be responsible for all obligations of the employer under the said act including the liability to make payments to apprentice as required under that said act.
10. A statement giving particulars of equipment resources that will be put at the disposal of the work under the following classification should accompany the tender.
 - a) Equipment (Transport of materials viz. lorries and carts, concrete mixers)
 - b) Organisation
 - (i) Technical & (ii) Unskilled
11. The tender of the contractor who agrees to employ the maximum No. of Ex. service Men (No. to be specified in the tender) will receive preferential consideration. The tenderers are requested to report on their covering letter.
12. The Managing Director reserves to himself the right of allotting the different sub works to the different contractors or to one and the same contractor as he may decide after the receipt of tenders.

13. All rates quoted in the tender shall be inclusive of Sales Tax,/GST payable under the sales tax act as amended from time to time (including amendment Act 38/34) and that the contractor is responsible to file the Sales Tax return and pay the amount of tax as amended by the Commercial Tax Department. No request for payment of Sales Tax ,GST separately in addition to the tendered rates due to any plea of subsequent levy or increase in tax will be entertained vide clause 38(2) of General conditions of contract.
14. No seigniorage shall be charged where due for materials quarried from the PWD or other Govt. Quarries. Assistants as necessary shall be given to the contractor by the Department to obtain access to quarries approved by the Departmental Engineer. No plot rent will be charged for materials stocked on Govt. land during the course of construction provided all such materials are removed within one month after the work is completed.
15. Seigniorage or charges due for the use of private quarries and private land shall be paid by the contractor.

III. Execution of Work

1. The entire work should be carried out as per specifications in the National Buildings code and Tamilnadu Building Practice.
2. The contractor shall make his own arrangements for clean and fresh water and shall meet all charges therefore. The special attention of the contractor is drawn to clause 36 of General Conditions of Contract regarding water and lighting.
3. The rates specified in schedule for the different items of works are for the finished work.
4. The contractor's rates are inclusive of Sales Tax payable by the contractor to Govt, as per the Tamilnadu General Sales Tax Act of 1939 as amended from time to time. No enhanced rates will be paid to the contractor for any upward revision of Sales Tax during the currency of the contract.
5. All minor baling and pumping incidental on the work shall be borne by the contractor, where heavy pumping is required the baling will be done departmentally.If the contractor is asked to do, the charges will be paid as per actual plus 10%. The Departmental Engineer in charge of the work will be the final authority to decide whether pumping is minor or heavy.
6. The cement concrete for reinforced cement concrete works shall be machine mixed.

Contractor

Managing Director,
T.N.H.W.C.S.LTD,CHENNAI

7. The lime mortar shall be ground in mortar mill as per T.N.B.P.
8. More than 90 cm height of concrete should not be laid in one day. At the place where the concrete is stopped, it should end in the form of steps so as to facilitate receiving of the next length of concrete. Once a height of 90 cm of concrete is laid, it should be cured for three days before further concrete is laid.
9. The teakwood or country wood (Karimarudhu or Pillaimarudu) shall be of best quality and shall be subject to inspection and approval by the Departmental Engineer before use on the work.
10. PAINTING : Paint used for the work shall be of approved brand and colour.
11. Plastering : All external corners, "TEE" beam edges and doors and windows opening etc, shall be finished truly vertical or horizontal as the case may be. The rate for plastering shall include the cost of finishing. No separate extra for finishing the corners edges of beams etc. will be paid.
12. The planks for form work and centering for reinforced cement concrete works shall be well seasoned timber approved by the Departmental Engineer according to clause 8 of T.N.B.P. No. 30. They must be made smooth and perfectly level at top so as to give smooth and even finish to the reinforced cement concrete ceilings. Alternatively, the contractor may use steel sheets over wooden frames provided the required finish to the underside of the slab is obtained. Mango Planks shall not be used under any circumstances. Centering form works shall be provided to the extent and area ordered by the Departmental Engineer during the execution.
13. The arrangements of steel rods for reinforcement for reinforced concrete works shall be in accordance with the working drawing supplied.
14. The Managing Director will be at liberty to carryout any portion of the work at any time either departmentally or through any other agency in the interest of TNHWCS Ltd. without assigning any reasons therefore to the contractor who is actually doing the work. The contractor is not entitled for any comprehension on account of the same. The contract will be only subject to this condition.
15. Earth work : Each and every borrow bit will be individually marked by the Section Officer and in urgent cases by the Masteries incharge of the work subject to the approval of the Section Officer. Earth should be removed only from the places marked and to the depth ordered by the above officer.
16. The contractor should not enter any private lands for removal of earth there from without the prior written consent of the landowners. If he does unauthorisedelly, the contractor alone will be held fully responsible for consequences arising there from.

IV. SUPPLY OF MATERIALS

1. The contractor's rate for the different items of work involving the use of cement are inclusive of the cost of Cement
2. The cement required for the work will be supplied by the contractor himself
3. The contractor should make his own arrangement at his own cost to take delivery of the cement from the dealer and to convey the same to his store shed at site of work. The stock of cement with contractors should be accessible to the Departmental Officers for verification at any time.
4. To be procured from authorised stockiest and dealers with details of printing in the Cement bag as approved by ISI (Pozzolona Cement printed in red colour and other Cement bags including OPC in black colour)
5. All Cement quantity should be supplied in paper bags only at site of work.
6. Test certificate to be obtained from Govt institutions and Quasi Govt institutions only by mentioning the name of work & period of contract and should not be from private institutions.
7. The minimum content of cement is to be ensured in use for works as specified in IS : 450-1978 Table - 19.

8a. TABLE - PHYSICAL CHARACTERISTIC REQUIREMENTS OF CEMENT (OPC)

SI. No.	Characteristics	Requirements		
		33 Grade IS: 269-	43 Grade IS: 8112-	53 Grade IS : 12269-
1.	Minimum compressive strength in N/ Sq. mm			
	3 days	16	23	27
	7 days	22	33	37
	28 days	33	43	53
2.	Fineness (minimum) (Sq. m/Kg)	225	225	225
3.	Setting Time (minutes)			
	Initial - (minimum)	30	30	30
	Final - (maximum)	600	600	600
4.	Soundness, Expansion			
	Le Chatleier - (maximum) m	10	10	10
	m Autoclave Test (maximum) %	0.80	0.80	0.80

Contractor

Managing Director,
T.N.H.W.C.S.LTD,CHENNAI

9. Steel required for the work will be supplied by the Contractor himself
10. No separate charges will be paid to the contractor for straightening of mild steel rods. The contractor shall make his own arrangements for cutting to sizes, bindings and tying grills etc. Mild steel rods, should be cut and placed as reinforcements with proper care according to the available rods at site so as to ensure minimum possible wastage.
11. To be procured from authorised dealers and test certificate for strength as well as for unit weight to be produced before use in order to ascertain the size of rod and quantum of Steel actually used in the work.
12. Excessively rusted Steel rods should be rejected.
13. To be delivered at site of work and to be under the custody of contractor only.
14. Use of Steel rods shall confirm to the structural designs approved for the work.
15. Steel supplied shall confirm to standard specifications specified in Table : 16 of IS : 456-1978 as detailed below :
 - a) Mild Steel - Grade I of IS : 432/Part 1/1966.
 - b) HYSD bars - IS : 1786 - 1985/
 - c) Cold worked - IS : 786-1979 (Grade Fe 415)
16. Steel manufactured from the waste Steel through the process of re-rolling shall be rejected since guarantee for the strength and quality is not certified by the authorised dealer or by the manufacturers.

CENTERING WORKS

17. Payments for centering works for all R.C.C. items shall be made only after concrete is laid, even though separate rate is called for, for centering work in the Schedule.
18. The contractor will be held responsible for the proper safe custody of all the Departmental materials which are handed over to the contractor until they are finally used on the work or taken over by the Department.
19. The shed for storing materials should be put up by the contractor at his own cost.

V. Special Conditions for Earthwork Excavation in Hard Rock Requiring Blasting

In the case of earthwork excavation in hard rock requiring blasting the tenderer should observe the following conditions.

a. The blasted rock shall be compactly stacked for measurement. The net quantity of blasted rock shall be arrived at by allowing a deduction of 40% for voids and compared with the pre-measured quantity and only the lesser of the Two shall be paid.

Where the rock other than hard rock and hard rock are mixed upon ground, the Two kinds of rocks shall be stacked separately for measurement. The net measurement of two kinds of rock shall be compared with the pre-measured quantity and only the lesser of the Two shall be paid for. If the total of net measurement of the two kinds of rock exceeds (or) falls short of the measurements of mixture, the volume of mixture proposed to be paid shall be apportioned in the proportion of the net actual measurements of stacks of the Two kinds of rocks.

- Note :
- i) 40% deduction for voids shall be adopted for compact and proper stacking but such percentage of deduction shall be increased for loose (or) improper stacks.
 - ii) The blasted rock material, stacked, measured and paid for shall become the property of the department.
 - iii) I.S. Code No. 1200 (Part I) 1969 method of measurement of buildings and Civil Engineering of work. Part I "Earthwork" may be referred as and when necessary.

VI MOSAIC FLOORING

1. Cement concrete flooring tiles shall be manufactured from a mixed cement natural aggregates and colouring materials where required by pressure process. During manufacture the tiles shall be subjected to a pressure of not less than 140 kg. per sqm. (or) 2000 lbs. sq.inc)
2. Proportion of cement to aggregate in backing of the tiles shall be not less than 1:5 by weight.
3. On removal from mould, the tile shall be kept in moist condition continuously for at least 7 days and subsequently if necessary kept in moist for such a longer period that would ensure their conformity, to the requirements of Traverse strength, Resistance to wear and tear absorption and would minimize shrinkage and cracking. Tiles shall be stored under cover.

4. TOLERANCE : Tolerance on length and breadth shall be plus or minus one millimeter.

Thickness of Wearing Layers

<i>Class of tiles</i>	<i>Minimum thickness of wearing layer</i>
Plain cement and plain coloured tiles for general duty	mm 3
Plain cement and plain coloured tiles for heavy duty	6 5
(Mosaic) terrace tiles with chips of size varying from the smallest upto 6mm (1/4")	5

5. Colours and Appearance : The colour and texture of the wearing layer shall be uniform throughout its thickness.
6. When specifying the tiles, the contractor should specifically indicate whether the chips to be used are from the smallest units 6mm from smallest upto 12mm or from the smallest upto 200mm size. The officers of the department shall also specify size of chips by referring the approximate photograph given in figure 4 to figures 6 in Indian Standard 1237/1959.

CONTRACTOR

THE MANAGING DIRECTOR
CO-OPTEX LTD, HEAD OFFICE,
NO:350,
Pantheon Road Egmore, Chennai 600
008.

Contractor

Managing Director,
T.N.H.W.C.S.LTD,CHENNAI

8.b. Cement Conditions :

The Procurement of cement of required specifications for the works subject to the followings.

- A. The contractor shall procure cement required for the works only from reputed cement factories (main producer or their authorized agents, manufacturing cement to ISI standard) acceptable to the Engineer-in-charge. The contractor shall be required to furnish to the Engineer-in-charge bills of payment and cost certificates issued by the manufacturers or their authorized agents to authenticate procurement of quality cement from the approved cement factory.
- B. The contractor shall procure in standard packing of 50Kg. Per bag bearing manufacturers. The contractor shall make necessary arrangement at his own cost to the satisfaction of Engineer-in-charge for actual weightment of random sample from the available stock and shall conform with the specification laid down by the Indian Standards Institution as the case may be cement shall be got tested for all the tests including through destructive and non-destructive test materials etc, as directed by the Engineer -in-charge in advance before the use of cement bags. In case test results indicate that the cement arranged by the contractor does not conform to the relevant code, the same shall stand rejected and shall be removed from the site by the contractor at his own cost within a day's time of written order from the Engineer -in-charge to do so.
- C. The employer will furnish air recreating agents and admixtures required to the Contractor free of cost at the employer stores. The use of such admixtures and agents shall be made as per the instructions of Engineer -in-charge. The cost of Cartage / Storage, handling, batching mixing shall be borne by the Contractor and shall be included by him to unit officers tendered for concrete.
- D. The cement shall be brought at site in bulk of approximately 50 tones or as decided by the Engineers-in-charge for large works
- E. The Cement Go down of the capacity to store a minimum of 1000 bags of cement shall be constructed by the Contractor at site of work, for which no extra payment shall be made. The Contractor shall facilitate inspection of the Cement Go down by the Engineer -in-charge at any time.
- F. The Contractor shall further at all times satisfy the Engineer-in-charge on demand by production or records and test book or by submission of returns and other proofs as directed that the cement is being used as tested and approved by the Engineer -in-charge for the purpose and the Contractor shall at all times, keeps his record up to date and enable the the Engineers -in-charge to apply such checks as he may desire.

- G. Cement which has been unduly long in storage with the Contractor or alternatively has deteriorated due to inadequate storage and thus become unfit for use on the works will be rejected by the Department and no claim will be entertained. The Contractor shall forth with remove from the work area any cement the Engineer-in-charge may disallow for use of work and replace it by cement complying with the relevant Indian Standards

GENERAL CONDITIONS OF CONTRACT

A. PREFACE

I. Intent and reference to TamilNadu Building Practice It is intended by these Tamilnadu Practice to describe;

- a. The character of the materials to be used
- b. The method of execution of work and
- c. The contractor's responsibilities to the Public, Govt and his workmen and general contract conditions which are to be accepted by every contractor who executes work entrusted to him by the Department.

12 Wherever the term "Standard Specifications" or "Specifications" of the abbreviation "T.N.B.P. No" or "TNBP" is used in the specifications or in estimates or contract documents, it shall refer to the relevant specification in the Tamilnadu Building Practice.

1.3 The abbreviation "I.S." shall mean 'Indian Standard'

2. Applicability of the Tamilnadu Building Practice

2.1 It shall be unnecessary to include in any contract documents a specification for any item of work which is defined in the tender notice or in the contract schedule of work to be done by a Tamilnadu Building Practice number (TNBP No.)

The fact that the item is defined as specification, shall mean that the contractor is to execute the work according to such specification modified as may be necessary by an addendum specification for that particular item of work. In the absence of specification for any work or material in the T.N.B.P. such work should be carried out

Contractor

in accordance with the instruction given by Departmental Engineer.

2.2 THESE GENERAL CONDITIONS OF CONTRACT SHALL APPLY TO ALL AGREEMENTS ENTERED INTO BY CONTRACTORS WITH THE OR HIGHWAYS AND RURAL WORKS DEPARTMENT AND shall form an inseparable condition of contract and it shall not be necessary to append a copy of the same to the agreement.

3. Contractor to sign in theal (or the Sub-al) copy of the T.N.B.P.

3.1 Every Contractor who executes work for the or the Highways and Rural Works Department shall carefully study the specification for all items of work which are included in the schedule for work to be done and his obligation under the "General Conditions of Contract" which apply to all agreements, and he shall sign in theal Office copy of the T.N.B.P. (or the Sub-.....al Office copy if so arranged by the Departmental Engineer) as evidence that he understands clearly the conditions of contract governing his agreement and accepts the same.

32 It shall not be necessary for the contractors to sign theal Office copy of the T.N.B.P. for every contract awarded to him, but his signature therein will be evidence that he accepts the conditions of contract (which include the specifications) as detailed in the T.N.B.P. for every contract into which he enters. It shall also be the

Managing Director,
T.N.H.W.C.S.LTD, CHENNAI

contractor's responsibility by frequent perusal of theal Office (or the Subal Office) copy to become conversant with sanctioned alterations or additions made to the T.N.B.P. as soon as they are made. A separate volume of addenda to the T.N.B.P. will be maintained in each (or sub office) as the case may be, in which will be entered all sanctioned corrections and additions. This must also be studied and signed by every contractor before executing an agreement. Interleaving corrections slips will not be made for this purpose. The contractor should purchase copy of the T.N.B.P. for his reference while executing work.

4. Sub-specifications

4.1 Works of similar nature having many common clauses in their specifications are grouped under one specification number with a "General" preface thereto and the sub-specifications are therefore given an alphabetical affix.

5. Additions and alterations to the T.N.B.P.

5.1 Additions and alterations to the T.N.B.P. will be incorporated in the addenda volume as authorised by the Chief Engineer.

6. Power of The Managing Director and TNWHCS Ltd

6.1 Departmental Engineer and Departmental Engineer may alter the specification for any particular contract which is within their respective power of sanction, when such alteration is found necessary by attachment of a correction sheet to the contract form, bearing the Contractor

T.N.B.P. number, the corrections and the signature of Departmental Engineer or Departmental Engineer as the case may be, together with the signature of the contractor. Similarly additional specifications for items for which there are no standard specifications will be made by attachment to the contract documents of addendum specifications sheets bearing the signature of theor the Departmental Engineer as the case may be and the signature of the contractor.

A-1. DEFINITIONS AND INTERPRETATIONS

7. Definition of terms

7.1 Wherever the words and expressions defined in this clause or pronouns used in their stead occur in contract documents (which includes the T.N.B.P) they shall have the meanings hereby assigned to them except where the context otherwise requires :

a) "Departmental Engineer " means Departmental Engineer for the time being in charge of the. concerned work under execution or such other departmental assistants or subordinates to whom Departmental Engineer may have delegated certain duties, acting severally within the scope of the particular duty entrusted to them.

Contractor

Managing Director,
T.N.H.W.C.S.LTD,CHENNAI

b) No delegation by The Managing Director which affects agreements

it is however, to be distinctly understood that Departmental Engineer or the higher authority who is vested with the powers of acceptance of the particular agreement under reference will make no delegation of powers to such assistants or subordinates with in any way affects the agreement and its contract condition when such agreement is to be or has been accepted by Departmental Engineer or by the other higher authority respectively. The duties of such assistants or subordinates will be solely duties of supervision to ensure compliance with contract conditions.

c) "Contractor means the particular persons firm or corporation with whom an agreement has been made by Departmental Engineer or higher authority as the case may be, for executing work defined in the concerned agreement and for purpose of instructions regarding compliance with contract conditions, it shall include the contractor's authorised agent, who is maintained on the work by the contractor.

d) Works or work means the works by or by virtue of the contractor contracted to be executed whether temporary or permanent and whether original, altered substituted or additional or connected with the supply repairs or carriage of tools. and plant and supply of manufacture of other stores.

12 Works importing the singular only also include the plural and vice-versa where the context requires.

NOTE: The terms section officer Assitant Departmental Engineer, Departmental Engineer, Departmental Engineer and Chief Contractor

Engineer, used in the following clauses shall where the context so requires, be construed as also including officers of the corresponding grade in the Highways and Rural Works Department.

8. Evidence of Experience

Tenderers shall, if required, present satisfactory evidence to the Departmental Engineer that they have been regularly engaged in constructing such works, as they propose to execute and that they are fully prepared with the necessary capital, machinery and materials to begin the work promptly and to conduct it as required by T.N.B.P. and the other specifications for the particular work if tendered for, in the event of their tender being accepted.

9. Legal address Notices

9.1 Tenderers should give in their tender their place of residence and postal address. The delivering at the abovenamed place or posting in a post box regularly maintained by the Post Office Department or sending by letter registered for acknowledgement of any notice, letter or other communication to the contractor shall be deemed sufficient service thereof upon the contractor in writing as may be changed at any time by an instrument executed by the contractor, and delivered to Departmental Engineer.

9.2 Nothing contained in the agreement and its contract conditions shall be deemed to preclude or render inoperative the service of any notice, letter or other communication upon the contractor personally.

B. STATEMENT OF APPROXIMATE QUANTITIES IN SCHEDULE – A

10.1 The quantities mentioned in tender notices and in agreement schedule - A, are worked out from the relevant drawing in office and may or may not be the actuals required for execution. Departmental Engineer does not be the expressly or by implication agree that the actual amount of work to be done will correspond therewith but reserves the right to increase or decrease the quantity of any class or portion of the work as he deems necessary.

10.2 Tenderers must satisfy themselves by a personal examination of the site of the proposed work, by examination of the plans and specifications and by other means as they prefer as to the accuracy and sufficiency of the statement of quantities and all conditions affecting the work and shall not at any time after the submission of their tender, dispute or complain of such statement of quantities or assert, that there was any misunderstanding in regard to the nature or amount of the work to be done nor in consequence apply for extension of time for completion beyond the agreement date.

11. Approximate not to mean deviation from drawings and specification

11.1 This declaration of the approximate, nature of the statement of quantities in Schedule. A does not, however, in any way imply that the quantities will be increased for departure by the contractor from strict compliance with sanctioned drawings and specifications to suit his own convenience or reduce his costs.

12. To compare tenders

12.1 The quantities in Schedule - A are given for a uniform comparison of lump-sum tenders.

C DRAWINGS AND SPECIFICATIONS

13. Purpose

13.1 The contract drawing if any, read together with the contract specifications are intended to show and explain the manner of executing the work and to indicate the type and class of materials to be used.

14. Conformance

The works shall be carried out in accordance with the drawings and specifications which form part of the contract and in accordance with such further drawings, details and instructions, supplementing or explaining the same as may from time to time be given by Departmental Engineer.

14.2 If the work shown on any such further drawings or details, or other work necessary to comply with any such instructions, directions, or explanations, be in the opinion of the contractor, of a nature which the schedule rate in the contract does not legitimately cover he shall before proceeding with such work, give notice in writing to this effect to the Departmental Engineer and contractor failing to agree as to whether or not there is any excess rate to be fixed and Departmental Engineer deciding that the contractor is to carry out the said work, the contractor shall accordingly do so, and the question whether or not there is any excess and if so the amount thereof, shall failing agreement, be settled by an arbitrator as provided in the arbitration clause, unless the subject is one which is left to the sole

discretion of Departmental Engineer under the clauses of these conditions of contract and the contractor shall be paid accordingly.'

14.3 It shall be the responsibility of the contractor to give timely notice to Departmental Engineer regarding anything shown on the drawings and not mentioned in the specification, or mentioned in the specifications and not shown in the drawings or any error or discrepancy in drawings or specifications and obtain his orders thereon. Figure dimensions are to be taken and not those obtained from scaling the drawings. In any discrepancy between drawings and specifications, the contractor shall forthwith apply to Departmental Engineer for such further instructions, drawings or specifications as he requires it, being understood that the subject to be dealt with under the building procedure of best modern practice. Departmental Engineer will furnish instructions, drawings or specifications if in his opinion, they are required by competent workmen, for the proper execution of the work.

15. Variations by way of modifications, omissions or additions.

15.1 For all modification, omissions from or additions to the drawings and specification, Departmental Engineer will issue revised plans, or written instructions or both and no modification, omissions or additions shall be made unless so authorised and directed by Departmental Engineer in writing.

15.2 Departmental Engineer shall have the privilege of ordering modifications, omissions or additions at any time before the completion of the work and such orders shall not operate to annul those portions of the specifications with which said changes do not conflict.

Contractor

15.3 The contractor shall submit to Departmental Engineer a statement giving details of the claims' for any additional work within 30 days of the work and no claim for any such work will be considered which has not been included in the statement.

16. Copies of Drawing and Specifications

16.1 One copy of the available drawings and specifications (apart from the T.N.B.P. a copy of which the contractor should purchase for his reference) shall be furnished free of cost to the contractor for his own use. Such copies of supplementary details furnished by the Departmental Engineer shall be kept by the contractor on the work until the completion thereof, and the Departmental Engineer shall at all times have access to them.

17. Signed drawing - No authority to the Contractor

17.1 No signed drawing shall be taken as in itself an order for variation, unless either it is entered in the agreement schedule of drawings under proper attestation of the contractor and the Departmental Engineer or unless it has been sent to contractor by Departmental Engineer, with a covering letter confirming that the drawing is an authority variation of the contract under reference.

D. MATERIALS AND WORKMANSHIP

18. To be the best quality

18.1 All materials, articles and workmanship shall be the best of their respective kind for the class of work described in the

Managing Director,
T.N.H.W.C.S.LTD, CHENNAI

contract specification and schedule materials being obtained from sources approved by Departmental Engineer. The word "best" as used in these specifications shall mean, that in the opinion of Departmental Engineer there is no other superior quality of materials or finish of articles on the market and that there is no better class of workmanship available for the nature of the particular item described in the contract schedule. The contractor shall, upon the request of Departmental Engineer, furnish him with the vouchers to prove that the materials are such as are specified.

18.2 Samples of materials shall be furnished at the contractor's expense to Departmental Engineer when called for in the tender notice or ordered to be furnished by Departmental Engineer prior to execution of any work.

19. Conversion for proportions

19.1 Wherever the proportions are written by figures without further description and where the meaning is otherwise clear as to which figure is intended to apply to each material, then the usual conventions will be understood to apply.

For example,
 1:2 Means 1 lime (or cement in accordance with the context) and 2 sand. 1:2:4 Means 1 lime (or cement in accordance with the context) 2 sand 4 broken stone (or other aggregate in accordance with the context).

20. Measurement and mixing

Contractor

20.1 In the case of loose materials such as lime sand, cement, broken stone, surki, motar, etc. the proportions demanded by the specifications must be measured in properly constructed measuring boxes or weighed or in such other manner as shall be instructed by Departmental Engineer. Measurement is not to be done in loose heaps when intimate mixtures such as motar concrete, etc., are to be formed. The mixing must always be done on closely constructed platform so that there will be no leakage of any of the materials through the floor of the platform and also that no foreign materials can be incorporated during the mixing. These platforms must be approved by the Departmental Engineer. The cost of such measuring boxes and platforms and all the work referred to herein shall be borne by the contractor.

21. Data

21.1 The materials and labour utilized in the execution of work by the contractor shall not be less than that given in the Tamilnadu state Public Work Department Standard Data for the relevant item.

NOTE In case the contractor considers that the materials and labour provided in the T.N.P. W.D Standard data for the execution of particular items of work are in excess, the contractor may furnish detailed data for such items along with tender with reasons for variations from Tamilnadu state Public Work Department. Standard Data.

22. Layout of materials stacks

22.1 The contractor shall deposit materials for the purpose of the work on such parts

Managing Director,
 T.N.H.W.C.S.LTD, CHENNAI

only on the ground as may be approved by Departmental Engineer. He shall submit for the approval of Departmental Engineer before starting work, a detailed site survey clearly indicating positions and areas where materials shall be stacked and sheds built.

23. Source of purchase of materials and stores

23.1 Departmental Engineer shall, during the progress of the work, have power to cause the contractor to purchase and use such materials or supplies from TNHWCS Ltd brick fields, stores or other sources as may be specified in the contract for the purpose therein specified.

24. Contractor liable for materials supplied by Government

24.1 The contractor shall be responsible for all materials and other articles and things which may be supplied by TNHWCSL from the time he takes delivery thereof and shall make good any loss, damage wastage or undue wear and tear that may take place from whatever cause and pay to TNHWCSL for such loss, damage, wastage or undue wear and tear such sum as Departmental Engineer may determine.

24.2 If at any time subsequent to the execution of the agreement TNHWCS Ltd materials other than those specified in the Agreement are to be supplied to the contractor for use on work they will be charged at the market value prevailing at the time of supply or stock issue rate whichever - ever is greater. The contractor will be informed in writing the rate which he demands for finished work in view of the fact that he is to use TNHWCS Ltd materials.

Contractor

25. Test inspection and rejection of defective materials and works

25.1 The contractor shall provide proper facilities at all times for the testing of materials and inspection of the work by Departmental Engineer shall accordingly also have access at all times to the places of storage or manufacture where materials are being made for use under the contract to determine that manufacture is proceeding in accordance with the drawings and specifications.

25.2 The contractor shall, upon demand, also forward for Departmental Engineer inspection test certificate supplied by the vendors, when he is purchasing consignments of cement, steel and other materials in respect of which certificates are usually available.

25.3 Departmental Engineer shall have power to reject at any stage, any work which he considers to be defective in quality of materials or workmanship and he shall not be debarred from rejecting wrought materials by reasons of his having previously passed them in an unworked condition. Any portion of the work or materials rejected or pronounced to be inferior or not in accordance with the drawing and specification, shall be taken down and removed from the work site at the contractor's expense, within 24 hours after written instructions to the effect have been given by Departmental Engineer. Replacement shall at once be made in accordance with the specifications and drawings at the contractor's expense.

Managing Director,
T.N.H.W.C.S.LTD, CHENNAI

25.4 In case of default on the part of the contractor to carry out such orders Departmental Engineer shall have power to employ and pay other persons to carry out the orders at the contractor's risk and all expenses consequent thereon incidental thereto shall be borne by the contractor.

25.5 In lieu of rejecting work **not** done in accordance with the contract, Departmental Engineer may allow such work to remain, and in that case shall make such allowance for the difference in value, as in his opinion may be reasonable.

25.6 Works opened for inspection:- The contractor shall, at the request of , Departmental Engineer, within such time as the Departmental Engineer shall **name**, open for inspection any work covered up and should the contractor refuse or neglect to comply with such a request Departmental Engineer may employ other workmen to open up the same. If the said work has been covered up in contravention of Departmental Engineer instructions or if on being opened up, it be found not in accordance with drawings and specifications or the written instructions of Departmental Engineer the expenses of opening it and covering it up again whether done by or recovered from the contractor. If the work has not been covered up in contravention of such instructions or if on being opened up it be found to be in accordance with the drawings and specifications or the written instructions of Departmental Engineer the expenses aforesaid shall be borne by TNHWCS Ltd and shall be added to the contract sum, provided always that in the case of Contractor

foundations, or any other urgent works so opened up and requiring immediate attention Departmental Engineer shall, within reasonable time after the receipt of a notice from the contractor that the work has been opened, make or cause the inspection thereof to be made, and at the expiration of such time if such inspection shall not have been made, the contractor may cover up the same, and shall not be required to open it up again for inspection except at the expense of Government.

26. Defects, shrinkages, etc, after completion

26.1 Any defects, shrinkage or other faults which may appear within six months from the completion of the works arising, in the opinion of Departmental Engineer from faulty materials or workmanship not in accordance with the drawings and specification or the instructions of Departmental Engineer shall, upon the directions in writing of the Departmental Engineer within such reasonable time as shall be specified therein, be amended and made good by the contractor at his own cost, Departmental Engineer shall decide that the contractor ought to be paid for the same at the rates agreed on such reduced or other rates, Departmental Engineer may fix and in case of default, Departmental Engineer may employ and pay other persons to amend and make good such defects, shrinkage or other faults or damage, and all expenses consequent thereon and incidental thereto shall be borne by the contractor.

26.1 (A) The shrinkage period of six months referred to in main clause 26.1 above, will

Managing Director,
T.N.H.W.C.S.LTD, CHENNAI

be five years in respect of all contracts for construction of original buildings either semi permanent or permanent to ensure structural stability of the building.

(G.O.Ms. No. 181 PWD 28.1.86)

262 Provided that in the event of TNHWCS Ltd taking over portions of the works as and when they are completed the liability of the contractor under this clause shall extend to a period of six months (or five years as the case may be) from the date of final taking over the of the work irrespective of the actual dates on which portion of the works were taken over.

27. Departmental Engineer's Decision

27.1 To prevent disputes and litigation, it shall be accepted as an inseparable part of the contract that in matters regarding materials workmanship, removal of improper work, interpretation of the contact drawings and contract specifications, mode of procedure and the carrying out of the work, the decision of Departmental Engineer shall be final and binding on the contractor and in any technical question which may arise touching the contract, Departmental Engineer decision shall be final and conclusive.

28. Dismissal of workmen

28.1 The contractor shall employ in and about the execution of the works only such persons as are careful, skilled and experienced in their several trades and callings and Departmental Engineer shall be at liberty to object to and request the contractor to remove from the works any person employed by the contractor in or Contractor

about the execution of the works who in the opinion of Departmental Engineer misconducts himself or incompetent or negligent in the proper performance of his duties and such persons shall not be again employed upon the works without the permission of Departmental Engineer **D.1**

GENERAL OBLIGATIONS

29. Contractor's maistri or agent and contractor's staff

29.1 The contractor shall in his own absence keep constantly on the works a competent maistry or agent and any directions or explanations given by Departmental Engineer or his representatives to such maistri or agent shall be held to have been given to the contractor. The contractor shall further provide all staff which is necessary for the proper supervision, execution and measurement of the work to ensure full compliance with the terms of the contract.

30. Government Maistries or agents

30.1 The TNHWCS Ltd may be represented oh the work by an agent clerk of the works, or maistri who is not borne on the official or officers and subordinates of the TNHWC Ltd., or Highways and Rural Works Department. He (if appointed) shall, in the absence of Departmental Engineer, furnish the contractor with Departmental Engineer or his representative's instructions of the works and the contractor shall duly comply with such instructions and directions to the progress and execution of the works and the contractor shall duly comply with such instructions and directions and shall on the

Managing Director,
T.N.H.W.C.S.LTD,CHENNAI

the written requisition of the maistri clerks of works or agent, stay the further progress of any portion of the works which in his judgment is being constructed with unsound or improper material or workmanship, until the opinion and determination of the Departmental Engineer shall be obtained thereon, but such maistri clerk of works or agent is to have no power whatever to order any extra works or deviation from the specifications and drawings.

E. INCLUDED IN CONTRACT RATES

3.1 Defining contract schedule rates

31.1 The rate entered in a contract schedule for any class of work shall be for finished work in situ and shall include all contingent expenses whether direct construction expenses involved in the building in place in accordance with the drawings and specifications or whether they be expenses imposed by an outside authority such as local body. Such contingent expenses shall not entitle the contractor to claim an extra in respect thereof.

32. Carriage

32.1 Rates for finished work shall always include the cost of conveyance and all leads, lifts, loading unloading and stacking in the manner and at the place ordered by the officer in immediate charge of the work, unless circumstances necessitate provisions for a separate schedule item, in which case for such will be specified in the tender notice or schedule.

322 Wherever the term "carriage" of "conveyance" is used in a schedule item, it shall in the absence of other schedule provisions or modifying description in the specification, be taken to include all leads, lifts loading, unloading and stacking in uniform stacks to the satisfaction of the Departmental Engineer with careful attention to close packing in case of materials which are to be measured in stacks as a basis of payment for finished work.

NOTE 1: In the case of important leads and lifts as may occur in river conservancy and other such works where lifts over flood banks and long leads may be involved, it is usual to make separate schedule item provision with a specification defining the exact work to be done for each tendered rate.

NOTE 2 : Payment for carriage will ordinarily be by bulk for weight at a rate between specified place and on the basis of the method adopted in the standard schedule of rates for carriage of materials. The distances will be measured by the nearest practicable and cheapest routes, whether metalled or unmetalled road or cart track.

32.3 When cart or vehicles of any sort are engaged by the day, the quantity of materials to be conveyed, the distance to be traveled and the number of trips to be made shall, if he considers necessary be fixed by Departmental Engineer.

32.4 The contractor is responsible for making good all loss in transporting materials entrusted to him or his agents, whether caused by wastage, breakage, theft or any other cause.

325. No payments shall, in any case, be made for the return trips with carts empty. Where there are loads also for the return trip the agreement rates should allow for the reduced cost thereby on each set of materials so conveyed.

33. Constructions plant

33.1 The contractor shall include in his tendered price and shall provide and install all necessary construction plant and shall use such methods and appliances for the performance of all the operations connected with the work embraced under the contract as will secure a satisfactory quality of work and rate of progress which in the opinion of Departmental Engineer will ensure the completion of the work within the time specified. If at any time before the commencement, or during the progress of the work, or any part of it such methods or appliances

appear to Departmental Engineer to be insufficient or inappropriate for securing the quality of the work required or the said rate of progress, he may order the contractor to increase their efficiency or to improve their character, and the contractor shall comply with such orders, but the failure of the Departmental Engineer to demand such increase of efficiency or improvement shall not relieve the contractor from his obligation to secure the quality of work and the rate of progress required by the contract and the contractor alone shall be responsible for the efficiency and safety of his plant, appliances and methods.

Contractor

33.2 It is however, open to Departmental Engineer to lend or supply to the contractor any tools, implements, materials and machinery that the Departmental Engineer may consider desirable but for any such tools, implements, materials and machinery that may be lent or supplied to contractor by Government, the contractor shall pay such deposit and hire, or purchase price as may be determined by the Departmental Engineer. All articles that may be so lent or hired to the contractor shall be returned in good serviceable condition by him to Departmental Engineer or before the final bill for work is paid and any shortage or damage shall be recovered from the contractor in the final bill at such rate as may be determined by Departmental Engineer after making such allowance as he may consider suitable for fan-wear and tear.

34. Scaffolding instructions

34. All requisite scaffolding shall be provided at the contractor's expense and shall be double, i.e. it must have two sets of upright supports. Care must be taken to ensure the safety of the work people and the contractor must comply with such instructions as the Public Work Department may issue to ensure such safety. The contractor will be entirely responsible for any damage or injuries to persons or property resulting from ill erected scaffolding, defective ladders, or otherwise arising out of his default in this respect. The contractor's attention also invited to the "safety code"

Managing Director,
T.N.H.W.C.S.LTD, CHENNAI

organic matter and from salts or other substances likely to interfere with the setting of mortar or otherwise prove harmful to the work.

35. Temporary structure

35.1 The Contractor shall erect and maintain at his own cost temporary weather proof sheds at such places and in a manner approved by Departmental Engineer for keeping materials under cover. The contractor shall also provide and maintain at his own expenses such temporary fences, guards, bridges and roads as may be necessary for the execution of his contract work or for safeguarding or accommodating the public. If Departmental Engineer shall order any departure from the arrangements made of the contractor, the contractor shall comply with such orders as Departmental Engineer may issue to safeguard or accommodate the public. Sheds for housing workmen shall be provided at the contractor's expense if, in the opinion of Departmental Engineer, such are necessary or desirable,

36. Water and Lighting

36.1 The contractor shall pay all fees and provide water and light as required from municipal mains or other sources and shall pay all charges therefore (including storage tanks, meters, etc) for the use of the work and workmen unless otherwise arranged and decided on in writing with the E.E. The water for the works shall be, so far as practicable, free from earthy vegetable, or Contractor

37. Sun protection keeping dry and pumping

37.1 The contractor shall at his own expense arrange all requisite protection of the work and materials against sun or rain effects and shall keep all portions of the work free from water to the satisfaction of Departmental Engineer and shall use his own plant for the purpose unless otherwise specifically provided in the contract specification.

38. Tools and Seigniorage

38.1 The contractor shall, unless otherwise specifically stated in the tender notice and subsequently on this basis in the contract be responsible for the payment wherever payable of all import duties, tolls, octroi duties, seigniorages, quarry fees, etc. on all materials and articles that he may use.

38.2, The contractor shall be solely responsible for the payment of sales tax under the provision of Madras General Sales Tax Act 1939 (Madras Act IX of 1939) as in force for time being and the rates for the various items of the work shall remain unaffected by any change that may be made from time to time in the rate at which such tax is payable.

38.3 Notwithstanding anything's contained in section 10 of the Indian Traffic Act, of 1894, the rates for items involving, the

Managing Director,
T.N.H.W.C.S.LTD, CHENNAI

use or supply of articles obtained' by the contractor from outside India shall remain unaffected by any changes that may be introduced in Customs duties.

NOTE : For works carried out on behalf of the Government of India, Seigniorage fees, etc, referred to in this clause will have to be levied in every case.

department to obtain access to quarries approved by Departmental Engineer. No plot rent shall be charged for materials stacked on the Government lands during the course of construction provided all such materials are removed within one month after the work is completed.

38.5 Seigniorage charges due for use of private quarries and private land shall be paid by the contractor.

38.6 The contractor shall form his own approach road to the worksite for which no extra will be due to him. On completion the contractor shall not be permitted to remove the materials laid for formation of road. If the contractor is allowed to use the existing roads he shall maintain them in good condition at his own cost through out the period of the contract.

39. Setting out works

39.1 The contractor shall be responsible for the true and proper setting out of the works and for the correctness of the position,
Contractor

levels, dimensions and alignment of all parts of the works and for the provision of all materials, staff and labour in connection therewith.

40. Cleaning up during progress and for delivery

40.1 All rubbish shall be burnt or removed from the site, as it accumulates. All floors, stairs, landing windows, surface and soil drains shall be cleaned down and put in a thoroughly complete clean, sound and workman like state to the satisfaction of Departmental Engineer before the work is finally handed over all rubbish and surplus materials not required by Departmental Engineer having first been removed by the Contractor. The contractor shall be give notice in writing to Departmental Engineer when the work is so ready to be handed over and shall be responsible for its maintenance until it is taken over by Departmental Engineer.

F. RESPONSIBILITIES AND LIABILITIES OF THE CONTRACTOR

41. Observance of laws, local regulations and notices, Attachments

41.1 The contractor shall confirm to the regulations and bylaws of any local authority and or of any water or lighting companies with those systems the structure is proposed to be connected and shall before making any variations from the drawings and specification that may be necessitated by so confirming, give to Departmental Engineer written notice., specifying the variations proposed to be made and the reasons for making them and apply for instructions,

Managing Director,
T.N.H.W.C.S.LTD,CHENNAI

thereon. In case the contractor shall not received such instruction within seven days, he shall proceed with the work confirming to the provisions regulating or by-law in question and variation in the drawing or specifications so necessitated shall be dealt with under clause 59.

412 The contractor shall give all notices required by the said Act, regulations or by-laws and pay all fees in connection therewith unless otherwise arranged and decided on in writing with Departmental Engineer. He shall also ensure that no

attachments are made against materials of work forming part of or for the use of the contract. In every case referred to in this clause the contractor shall protect and indemnity Government against any claim or Liability arising from or based on the violation of any such law, ordinance, regulation order, decree, or attachment whether by himself or by his employees.

42. Accidents - Hoarding - Lighting Observations –Watchmen

42.1 When excavations have been made or obstacles have been put in public thorough fares or in places where there is any likelihood of accidents, the contractor shall comply with any requirement of law on the subject and shall provide suitable hoarding lighting and watchmen as necessary.

42.2 It shall be contractor's sole responsibility to protect the public and his employees against accident from any cause and he shall indemnify TNHWCS Ltd against any claims for damages for injury to person or property, resulting from any such accident and shall where the provisions of the Workmen's Compensation Act apply take steps to properly insure against any claims there under.

42.3 On the occurrence of accident which results in the death of any of the workmen employed by the contractor or which so serious as to be likely to result in the death of any such

workmen, the contractor shall within 24 hours of the happening of such accident, intimate in writing to the concerned section officer of Department the fact of such accident. The contractor shall indemnify TNHWCS Ltd against all loss or damage sustained by government resulting directly or indirectly from his failure to give intimation in the manner aforesaid including the penalties of fines if any payable by TNHWCS Ltd as a consequence of TNHWCS Ltd failure to give notice under the Workmen's Compensation Act or otherwise confirm to the provisions of the said Act in regard to such accident.

42.4 In the event of an accident in respect of which compensation may become payable under the Workmen's Compensation Act VIII of the 1923 whether by the contractor or by the TNHWCS Ltd as principal it shall be lawful for Departmental Engineer to retain out of money due and payable to the contractor such sum or sums of money as may, in the opinion of the said Departmental Engineer be sufficient to meet such liability. The opinion of the Departmental Engineer shall be final in regard to all matters arising under this clause.

42.5 The contractor shall indemnify TNHWCS Ltd from and against all claims and proceedings for or on account of infringement of any patent rights, design, Contractor

trade mark, or name or other protected rights in respect of any constructional plant, machine work or materials used for or in connection with the works or temporary works, or any of them and from and against all claims, demands, proceedings, damages, costs, charges and expenses whatsoever in respect thereof in relation thereto.

42.6 In respect of all labour directly or indirectly employed in the works for the performance of the contractor's part of this agreement, the contractor shall comply with or cause to be

complied with all the rules framed by the TNHWCS Ltd from time to time for the provision of health and sanitary arrangements to workers employed by and Highways and Rural Works Department and their contractors (vide appendix) In case the contractor fails to make arrangements and provide necessary facilities as aforesaid Departmental Engineer shall be at liberty to make arrangements and provide facilities as aforesaid and recover the costs incurred in **that** behalf from the contractor.

42.7 In respect of all labour directly or indirectly employed in the works for the performance of the contractor's part of this agreement, the contractor at his own expense shall arrange for the safety provisions as per "Safety Code" framed from time to time and shall at his own expense provide for all facilities in connection therewith. In case the contractor fails to make arrangements and provide facilities as aforesaid the Executive Engineer shall be at liberty to make arrangements and provide facilities as aforesaid and recover the costs incurred in that behalf from the contractor.

42.8 In respect of all labour directly or indirectly employed in the work for the performance of the contractors part of this agreement the contractor shall arrange to furnish in triplicate particulars for each work in the proforma Contractor

Vide Appendix XXXVIII by the end every month to Departmental Engineer in charge of the work.

43. Blasting

43.1 Blasting executed by contractors in connection with Government works shall be carried out in the manner described under "Blasting operation - Instructions to Contractor" of the TNBP.

44. Protection of Existing and Adjoining premises

44. The contractor is to protect the whole of the adjoining and where necessary, the existing premises and all works and all fittings to all buildings on and adjoining the site against the structural and decorative damages caused by the execution of these works and make good in all respects all such damage done or occurring to the same, and leave such reinstatement in perfect order. He is also to make good any damage done in the execution of the work to existing public or to private footways or roadways.

45. Permit other workmen – Co-operation - Afford Facilities

45.1 Departmental Engineer shall have full power to send workmen upon the premises to execute fittings and other works not included in the contract, for whose operations the contractor is to afford every reasonable facility during ordinary working hours, provided that such operations shall be carried on in such a manner as not to impede the progress of the work included in the contract, but the contractor is not to be

responsible for any damage which may happen to or be occasioned by any such fittings or other works, provided he complies with Departmental Engineer instructions in connections therewith, and provided that the damage is not caused by himself or his workmen.

452 The contractor shall, at all times co-operate assist, attend on, and afford facilities for such specialists as maybe employed

by Departmental Engineer on other works in connection with the building, allowing them free of charge the use of all plant, light and water installed in the works. The contractor shall also cause such special work or protect it as instructed to avoid injury during progress of the works. For failure so to protect, the contractor must make good any damage caused.

45.3 When two or more contractors are engaged on installation or construction work in the same vicinity the Departmental Engineer shall have authority to direct the manner in which each shall conduct the work so far as it affects other contractors.

46. Holes for water services, gas electrical and Sanitary fittings

46.1 The contractor shall leave all holes in masonry and floors for the insertion of water services, gas and electrical connections and sanitary fittings in the exact positions indicated by Departmental Engineer during the progress of work. These holes must be properly built up in a workman like manner at the contractor's cost, as soon as the fittings have been installed in cases, where the installations are made during the constructions of the building and where in the opinion of Departmental Engineer, delays in settlement of accounts will not thereby occur.

47. Contract's risk and insurance.

47.1 The work in TNHWCS Ltd executed by the contractor under the contract shall be maintained at the contractor's risk until the work is taken over by the Departmental

Engineer The contractor shall accordingly arrange his own insurance against fire, flood, volcanic eruption, earth quake, other convulsions of nature and all other natural calamities and risks arising out of acts of God during such period and that the Government shall not be liable for any loss or damages occasioned by or arising out of any such of God”

Departmental Engineer.

472 Provided however, that the contractor, shall not be liable for all or any loss or damages occasioned by or arising out of acts of foreign enemies invasion, hostilities or war like operations (before or after declaration of war) rebellion military or usurped power.

48. Holidays

48.1 Subject to any provision to the contrary contained in the contract name of the permanent work shall save as hereinafter provided be carried on during the night or on Sundays and other holidays without the permission in writing of the Departmental Engineer or of the officer in-charge of the work, save when the work is unavoidable or absolutely necessary for the safety of life or property or for the safety of the works in which case the contractor shall immediately advise the Departmental Engineer.

MISCELLANEOUS

49. Sand and Gravel

49.1 The contractor shall not make any excavations upon the site for the purpose of obtaining gravel, sand or soil other than that shown or implied by the drawings, except with the previous permission of Contractor

50. Old Curiosities

50.1 All old curiosities, relics, coins, minerals, etc., found in excavating or pulling down, shall be the property of the Government and be handed over to Departmental Engineer. Should any ancient masonry, or other old work of interest be opened up Departmental Engineer attention shall be called to the same before demolition or removal.

51. Assignment or sub-letting

51.1. The contractor shall not without the written consent of Departmental Engineer assign the contract nor sub-let any portion of the same. Ordinarily no sub-letting will be permitted, but in case such should be permitted by the Departmental Engineer, it shall in no way free the contractor from any of responsibilities under any clause of these "Conditions of Contract" or of the "Articles of Agreement"

52. Specialists

52. Departmental Engineer shall, during the progress of the work have powers to select, nominate or recommend tradesmen or specialists to supply material or execute such portion of the work as he may consider desirable in the interests of the Government.

53. Ratification of the orders of the Departmental Engineer

53.1 Should the acceptance of the tenders be beyond the authorised powers of Departmental Engineer as laid down the Building practice code, the orders and Contractor

decisions of such Executive

- Engineer with regard to
 - (a) extension of time for completing the contract will be subject to the ratification of Departmental Engineer for all works for which tenders were accepted by the Engineers of TNHWCS Ltd the termination of contract or of employment of specialists for certain portion of the works will be subject to the ratification of the Chief Engineer for all works for which tenders were accepted by Engineers of TNHWCS Ltd

54. Order Book

54.1 An order book shall be kept at the TNHWCS Ltd Office on the site of the work. As far as possible, all orders regarding the work are to be entered in this book. All entries shall be signed and dated by the Departmental Officer in direct charge of the work and by the contractor or by his representative. In important cases, Departmental Engineer or the Departmental officer of TNHWCS Ltd., will countersign the entries, which have been made. The order book shall not be removed from the work except with the written permission of the Departmental Engineer.

54.2 No photographs of the site or of the work or any part thereof shall be taken except with the permission in writing of Departmental Engineer and no such photographs shall be published or otherwise circulated without the permission of the Chief Engineer.

**H. DATE OF COMMENCEMENT,
COMPLETION,
DELAYS, EXTENSION, SUSPENSION
OF WORK AND
FORFEITURE**

55. Date of commencement and completion

55.1 On notification of possession of the site (or premises) being given to the contractor by letter registered for acknowledgement as provided in clause 9.1 supra, he shall forthwith begin the work, shall regularly and continuously proceed with them, and shall complete the same (except for painting or other work which, in the opinion, of the Departmental Engineer, it may be desirable to delay) by the date of completion, as defined in the "Articles of Agreement" subject nevertheless, to the provisions of extension of time mentioned in the next clause. The contractor shall under no circumstances be entitled to claim any damages from Government if he incurs any expenses or liabilities to payment under the contract before the date of commencement defined above. The contractor shall have the right to withdraw from the contract and obtain refund of his security deposit if such intimation of handing over the site is delayed by more than two months from the date of acceptance of the agreement by competent authority.

56. Delays and extension of time

56.1 No claim for compensation on account of delays or hindrances to the work from any cause whatever shall be except as hereinafter defined.

Contractor

Reasonable extension of time will be allowed by Departmental Engineer by the officer competent to sanction the extension for unavoidable delays, such as may result from causes which in the opinion of Departmental Engineer are undoubtedly beyond the control of the contractor. Departmental Engineer shall assess the period of delay or hindrance caused by any written instruction issued by him at twenty five percent in excess of the actual working period so lost. If at any time Departmental Engineer is of the opinion that there has been avoidable delays and the contractor fails to maintain the rate of progress specified in the articles of agreement, it shall be lawful for Departmental Engineer to impose penalty or order forfeiture from the Deposit and sanction the extension of time for such delays, provided however, the penalty and forfeiture shall be governed as per clause 57.2 and 57.3

56.2 In the event of Departmental Engineer failing to issue necessary instructions and thereby causing delay and hindrance to the contractor the latter shall have the right to claim an assessment of such delay by Departmental Engineer of TNHWCS Ltd., The contractor shall lodge in writing to Departmental Engineer a statement of claim for any delay or hindrance referred to above within fourteen days from its commencement otherwise no extension of time will be allowed.

56.3 Whenever, authorised alterations or additions made during the progress of the work are of such nature in the opinion of Departmental Engineer as to justify an extension of time in consequence

Managing Director,
T.N.H.W.C.S.LTD, CHENNAI

thereof such extension of time will be granted in writing by Departmental Engineer or other competent authority when ordering such alterations or additions.

AMENDMENT

(Issued in Govt Letter No. 2163/Y2/95-
l/dt.01.09.1996)

In the said preliminary specifications after clause 56.3 the following clauses shall be inserted, namely:

56.4 In cases where the TNHWCS Ltd under the terms of the contract with the contractor are liable to supply any materials, article or things to the contractor for the performance by him of his part of the contract, the Departmental Engineer, may at his absolute discretion extend the time with in which such materials, articles or thing maybe supplied by the TNHWCS Ltd, and the TNHWCS Ltd may supply to the contractor such materials, articles or things within the time so extended without any liability on their part to compensate the contractor by reason of the extension of time for the supply of the materials, articles or things.

56.5 In cases where the TNHWCS Ltd under the terms of the contract are liable to supply any materials, articles or things to the contractor for the performance by him of his part of the contract and the TNHWCS Ltd for any reason are unable to supply such materials, articles or thigs either within the time specified in the contract or within the time extended under clause 56.4 Departmental Engineer may at his discretion or at the request of the contractor determine the whole or any part of the contract which

cannot be performed by reason of the failure to supply such materials, articles or things and the contractor shall not be entitled to claim any damages or compensation in respect of such determination. The contractor shall however, be paid the value of the work already done by him and the cost of the materials articles or things if any collected by him up to the date of such determined and left unused on the work-spot (Which shall be taken over by Departmental Engineer r either at the contract rates or at values deducted form the through rates included in the contract) when the contract is determined at the discretion of Departmental Engineer, he shall give notice in writing to the contractor and the decision of Departmental Engineer to determine the contract shall be final and binding on the contractor

Explanation : The expression Through rules means the rate for the finished items of work or the allinrates that is to say, the rates for finished items of work inclusive of the cost of materials and labour

56:6 If, at any time after the acceptance of tender the Government shall, for any reason what so ever not required the whole or any part of the works to be carried out, Departmental Engineer shall give notice in writing of the fact to the contractor who hare no claim to any compensation or other payments what so ever, on account of any profit or advantage he might have derived from the Execution of of the work in full but which he did not drive in consequence of the termination of the works, he shall be paid at contract rates, for the work executed by him including any additional works such as clearing of site etc. may be rendered necessary by such determination. He shall

also be allowed a reasonable payment as decided by the authority which accepted the tender, for any expense incurred by him on account of labour and materials, articles or thing collected, but which could not be utilized on the works as verified by Departmental Engineer such decision shall be final and binding on both the parties and shall not be subject to arbitration under clause

57. Delays in commencement or progress or neglect of work or suspension of works by the contractor and forfeiture of Earnest Money, Security Deposit and withheld amount

57.1 Time shall be considered as the essence of the contract. If at any time Departmental Engineer shall be of the opinion that contractor is delaying commencement of the work neglecting or delaying the progress of work as defined in the tabular statement, "Rate of Progress" in the Articles of Agreement or the contractor fails to maintain the Rate of progress in the Articles of Agreement plus any extension of time or the contractor shall suspend the works, or sublet the work or a portion thereof without the sanction of the Departmental Engineer or violates any of the provisions of the contract Departmental Engineer shall so advise the contractor and at the same time demand compliance. If the contractor neglects to comply with such demand within seven days after receipt of such notice, it shall then or at any time be lawful for Departmental Engineer to impose a penalty or forfeiture on this contractor from the deposit or to determine the contract.

572 The penalty or forfeiture referred to in Clause 57. I shall not exceed 5% of the value of work executed and is imposed in cases where the contractor is allowed to proceed with the whole or part and complete the whole or such part of the works. The penalty or forfeiture imposed by the Executive Engineer under this clause is however subject to modification or waiver at the absolute discretion of any authority higher in rank than the Departmental Engineer. It shall be a further right of Departmental Engineer to give any part of the work to any other contractor at his discretion or have it done departmentally in order to maintain the rate of progress and the contract shall then be determined for only that portion of the work given to the other contractor or done departmentally. The forfeiture under clause 57.2 will in these circumstances be applied and any excess expenditure incurred on this account shall be recovered from the original contractor. 57.4

Determination of the contract referred to in Clause 57.1 shall carry with it the forfeiture of the Security Deposit. After determining the contract, Departmental Engineer shall have the right to give any part of the work to any other contractor in the unexecuted portion of contract, in which case any expenses which may be incurred in excess of such amount which would have been paid to the original contractor if the whole work had been executed by him shall be borne and paid by the original contractor and may be deducted from any money due to him by TNHWCS Ltd under this contract or any other amount what so ever Provided also that if the expenses incurred by the government

are less than the amount payable to the contractor at his agreement rate? the difference will not be paid to the contractor.

57.5 In the event of anyone of the above clauses being adopted by Departmental Engineer, the contractor shall have no compensation for any loss sustained by him by reason of his having purchased or processed any materials or entered into any engagements or made any advances on account or with a view to the execution of the work or the performance of contract, and in case action is taken under any of the provisions aforesaid, the contractor shall not be entitled to be paid any sum for any work actually performed under the contract unless and until Departmental Engineer has certified in writing the performance of such work and the value payable in respect thereof and he shall only be entitled to be paid the value so certified.

57.6 In the event of Departmental Engineer putting in force all or any of the powers vested in him under the clause 57.4 he may if he so desires after giving a notice in writing to the Contractor take possession of the works and site and all sue' plant and materials thereon (or any ground contiguous there to) and all such plant and materials as above mentioned shall thereupon be at the disposal of TNHWCS Ltd absolutely for the purpose of completing the work. After such notices shall have been given the contractor shall not be at liberty to remove from the site of works or from the ground contiguous thereto any plant or materials belonging to him which shall have Contractor

been placed thereon for the purpose of the above work. Government shall not be liable to make any payment to the contractor on account of use of such plant for the completion of the works under the provisions herein before contained. On taking possession of the materials and stores belonging to the contractor or procured by the contractor and intended to be used for the execution of the work or any part thereof the contractor shall be paid for the same in account, at the contract rates, to be certified there of shall be final. Otherwise the Government may give notice in writing to the contractor to remove any of his plant or materials from the site and not required for completion of the works, if such plant and materials are not removed with fourteen days after notice and have been so given, TNHWCS Ltd may remove and sell the same holding the proceeds less the cost of removal and sale, to the credit of the contractor. The certificate of Departmental Engineer as to expense of any such removal and sale shall be final and binding on the contractor.

1. PARTICULARS OF PAYMENT

58. Payment on lumpsum basis or by final measurement in unit prices

58.1 Final measurements need not be taken unless either the contractor or Departmental Engineer claims extras to or deductions from the quantities of schedule - A.

In case final measurements are claimed, they shall be taken only for those items for which either the contractor or Departmental Engineer claims final measurements and the quantities of the remaining items in Schedule-A shall be accepted as correct. The lumpsum amount mentioned in the

Managing Director,
T.N.H.W.C.S.LTD, CHENNAI

agreement will then be varied by adding thereto or deducting there from as the case may be, the difference (if any) between the amounts mentioned in Schedule-A for such items and the amounts arrived at by calculation at contract rates based on the revised quantities for the same, obtained by the final measurement aforesaid.

58.3 It shall be accepted as a condition of the contract that the payment of the final bill to the contractor less the withheld amounts and his acceptance thereof shall constitute a full and absolute release of TNHWCS Ltd from all further claims by the contractor under the contract.

59. Payment for additions and deductions for omissions

59.1 No authorised variation shall vitiate the contract, but additions and omissions shall be measured up and dealt with in accordance with clause 58.2'

59.2 If there is no rate in Schedule A for additional work ordered to be carried out by Departmental Engineer, then prior to execution of the additional work, a rate for the additional work, shall be worked out in accordance with the methods indicated in 59.3 and with the rate agreed upon a supplemental agreement shall be entered in the proper departmental form signed and dated by the contractor and the Departmental Engineer and or any other officer for the time being authorised to accept such agreement and supplemental agreement shall on such acceptance form part of the original agreement. A copy of the supplemental slip shall be given to the contractor.

59.3.1 The rate for additional works shall be derived from the rate for similar items of work in the accepted agreement.

59.3.2 In the case of works for which supplemental agreement is to be entered into during the period when the schedule of rates has not changed from the date of execution of the original agreement then the rates for supplemental agreements may be the prevailing schedule or rates plus or minus tender premium in case the rates" cannot be derived from the items in the original agreement. In other case, where the schedule or rates has changed in the intervening period, the rates prevailing as per the schedule of rates at the time of execution of supplemental items will be adopted with, no tender premium over this rate.

59.3.3 If the rate for a particular item of work is not in the schedule of rates, the prevailing market rate when the work has done shall be adopted.

59.3.4 If the rates cannot be determined as above, the rates shall be fixed on the cost of labour and materials plus 10 percent thereon, provided the vouchers shall have been delivered Departmental Engineer within 7 days after such work is completed. If Departmental Engineer considers that the vouchers are unduly high Departmental Engineer can value the work as reasonable and fair and make payment if the value of payment is less than Rs. 1,000. If the value of additional payment exceeds Rs. 1,000 the contractor shall have the right to submit matter to arbitration.

60. No payment for unsanctioned extras

60.1 It shall be distinctly understood that no payment whatever will be made to the contractor for variations by way of extras, in cases where such variations have been made within the written sanction of Departmental Engineer

61. Accounts Receipts and Vouchers

The contractor shall at any time upon the request of the Departmental Engineer furnish him with all invoices account, receipts and other vouchers that he may require in connection with the contract.

62. Fraud, willful neglect or default

62.1 No final or other certificate of payment or of completion, acceptance or settlement of account shall, in any circumstances, relieve the contractor from his liability for any fraud, or willful neglect or default in the execution of the contract or any willful or unauthorized deviations from drawings, specifications, instructions and directions for the time being binding upon him.

63. Unfixed materials

63.1 No payment or advance will be made for unfixed materials when the rates are finished work in situ.

64. Payments and Certificate

64.1 Payments will be made to the contractor under the certificates to be issued at reasonably frequent intervals by the Contractor

Departmental Engineer or the Departmental Officer, within 14 days of the date of each certificate an intermediate payment will be made by the . Departmental Engineer or the Departmental Officer of a sum equal to 95 percent of the value of work, as so certified and the balance of 5 percent will be withheld and retained as security for the due fulfillment of the contract.

Under the certificate to be issued by Departmental Engineer or Departmental Officer .on the completion of the entire works, the contractor will receive the final payment of all the money due or payable to him under or by virtue of the contract except security deposit and the withheld amount equal to 2 1/2 percent of the total value of the work done provided there is no recovery from or forfeiture by the contractor to be made under clause 57. The amount with held from the final bill will be retained under. Deposits and paid to the contractor together with the Security Deposit after one year reckoned from the date of completion of work or as soon after the expiration of such period of one year as all defects shall have been made good according to the true-intent and meaning thereof whichever shall last happen. In the event the final bill remains unpaid even after the period of one year aforesaid, the security deposit, which includes EMD and also 2 ½ % of the with held amount may be refunded under the sanction of the Departmental Engineer, in the case of agreements accepted by Departmental Engineer and under the orders / sanction of Chief Engineer concerned, in the case of agreement accepted byEngineer, or a bill, if requested for, by the contractor in writing to the sanctioning authorities viz Departmental

Managing Director,
T.N.H.W.C.S.LTD,CHENNAI

Engineer and Chief Engineer, who while according sanction should review the cause for delay in payment of the final bill.

No certificate of Departmental Engineer or Departmental Officer shall be considered conclusive evidence as to the sufficiency of any work or materials or correctness of measurements to which it relates nor shall it relieve the contractor from his liability to make good defects and provided by the contract. The contractor when applying for a certificate, shall prepare a sufficiently detailed bill based on the original figures of quantities and rates in the contract Schedule-A to the satisfaction of Departmental Engineer, to enable Departmental Engineer or the Departmental Officer to check the claims and issue the certificate. The certificates as to such of the claims mentioned in the application as are allowed Departmental Engineer or the Departmental Officer shall be issued within fourteen days of the application. No application for a certificate shall be made within fourteen days of a previous application.

64.1 (A) Notwithstanding the above clause, the withheld amount of 2 1/2% from the final bill in respect of contract for construction of original building, will be retained by TNHWCS Ltd the. for a total period of one year in lieu of six months period referred to in clause 64.1 above and will be released after the expiry of one year period on execution of an indemnity bond by Contractor

the contractor to the satisfaction of the Exe. Engr. for a further period of four years to ensure structural stability of the building under clause 26.1 A

64.2 When there are complaints from the labour Department about non-payment of wages to the labourers employed by the Contractor for the execution of works under agreement, the Departmental Engineer shall have full powers to withheld the bills claimed by the contractor pending clearance certificate from the Labour Department and to act as per the direction given by the Labour Department.

65. Interest on money due to the contractor

65.1 No omission by Departmental Engineer or the Departmental Officer to pay the amount due upon certificates shall vitiate or make void the contract not shall the contractor be entitled to interest upon any guarantee fund or payments in arrear, nor upon any balance which may, on the final settlement of his accounts, be found to be due to him.

65.2 Whenever the withheld amount reaches Rs. 1,000 or a multiple thereof, the contractor may, at his option, deposit with Departmental Engineer an equal amount in sums of Rs. 1,000 or a multiple thereof, in any of the forms of interest bearing securities recognized for the purpose by the TNHWCS Ltd. Account Code and subject to the provisions thereof contained in which case the equivalent withheld amount shall be paid to him forth with. The contractor will be permitted to exercise the option in this

Managing Director,
T.N.H.W.C.S.LTD, CHENNAI

clause, subject only to the condition that the rates of progress contained in the Articles of Agreement is properly maintained.

66. Acceptance of final measurements

66.1 The contractor agrees that before payment of the final bill shall be made on the contract, he will sign and deliver to the Departmental Engineer, either in the measurement book or otherwise as demanded a valid release and discharge from any and all claims and demands whatsoever for all matters arising out of or connected with the contract and also produce a certificate from the Income Tax Authorities that all income tax payable by him upto-date has been duly paid provided that nothing in this clause shall discharge or release the contractor from his liabilities under the contract. It is further expressly agree that Departmental Engineer in supplying the final measurement certificate need not be bound by the proceeding measurements and payments. The final measurements, if any of Departmental Engineer shall be final conclusive and binding on the contractor.

67. Recovery of money from contractor in certain cases

67.1 In every case in which provision is made for recovery of money from the contractor, Government shall be entitled to retain or deduct the amount thereof from any money, that may be due or may become due to the contractor under these presents and or under any other contract or contracts or any other account what so ever.

Contractor

67.2 Recovery under Revenue Recovery AQ

Whenever any amount has to be paid by the Contractor in view of the determination of the contract by virtue of clause 57 or any amount that may be due from the contractor is under these presents and the contractor is not responding to the demands for the payment of the said amount, then the Govt. shall be entitled to recover the said amount under the provisions of the Revenue Recovery Act.

68. Contractor dying becoming insolvent insane or imprisoned

68.1 In the event of the death or insanity or insolvency or imprisonment of the contractor, or where the contractor being a partnership or firm becomes dissolved or being a corporation goes into liquidation voluntary' or otherwise, the contract may at the option of Departmental Engineer, be terminated by notice in writing posted at the site of the works and advertised in one issue of the local district Gazette and all accepted and acceptable works shall forthwith be measured up and paid for at the rates provided in the contract schedule where such apply, or otherwise, by the most recent schedule of rate of the TNHWCS Ltd., approved by competent authority to the person or persons entitled to receive and give a discharge for the payment.

J. SETTLEMENT OF DISPUTES

69. Arbitrations

69.1 In case of any dispute or difference between the parties to the contract either during the progress or after - the completion

Managing Director,
T.N.H.W.C.S.LTD, CHENNAI

of the works or after the determination, abandonment or breach of the contract, or as to any matter or thing arising hereunder except as to the matters left to the sole discretion of the Departmental Engineer under clauses 18,20,25-3,27,34,35 and 37 of "General conditions of contract" or as to the withholding by the Departmental Engineer of payment of any bill to which the contractor may claim to be entitled, then either party shall forthwith give to the other notice of such dispute of difference and such dispute or difference shall be and is hereby referred to the arbitration of Departmental Engineer, of the nomination mentioned in the Articles of Agreement (herein after called the Arbitrator). The Arbitrator shall give detailed reasons in their awards for their findings and conclusion.

The arbitrator shall give detailed reasons in the awards for their finding and conclusions. Subject as aforesaid to the provisions of the arbitration Act, 1940 or any statutory modification or re-enactment thereof and the rules made there under and for the time being in force shall apply to the Arbitration proceeding under this clause.

Upon every and any such reference, the costs of and incidental to the reference and award respectively shall be at the discretion of the arbitrator, subject to the condition that the amount of such costs to be awarded to either party shall not, in respect of a monetary claim exceed the percentage set out below of any such award irrespective of the actual fees, cost and expense incurred by either party provided that where a monetary claim is disallowed in full the said percentage shall be calculated on the amount of the claim.

Contractor

The arbitrator may determine the amount of the costs to be awarded or direct the same to be fixed as between solicitor and client or as party and shall direct by whom and to whom and in what manner the same shall be borne and paid.

The percentage above referred to in this clause are 5% on any such monetary award which does not exceed Rs. 10,000.3% on the next Rs. 40,000 or any part thereof 2% on the next Rs. 50,000 or any part thereof and 1% on any excess over Rs. 1,00,000/- provided that the TNHWCS Ltd shall not be liable to any claim in respect of any such dispute or difference until the liability and the amount thereof shall have been referred to and decided by the Arbitrator.

69.2 The fees for Arbitrators shall be levied based on the value of claims referred to for arbitration. The fees shall be calculated at 5% of the first Rs. 10000/- at 3% of the next Rs. 40000/-

APPENDIX No. I.

General Rules as to Scaffolds;

1. Suitable scaffolds shall be provided for workman for all works that cannot be safely done from a ladder or by other means. When a ladder is used an extra Mazdoor shall be engaged for holding the ladder and the ladder shall be given an inclination not steeper than 0.25 to 1 (0.25 horizontal to 1 vertical) When the ladder is used for carrying materials as well, suitable foot holds and hand holds shall be provided on the ladder. , i

2. A scaffold shall not be constructed taken down or substantially altered, except (a) under the supervision of competent and responsible person; and (b) as far as possible by competent workers possessing adequate experience in such work.
3. All scaffolds and appliance connected therewith and all ladders shall
 - a) be of sound material
 - b) be of adequate strength having regard to the load strain to which they will be subjected and
 - c) be maintained in proper condition
4. Scaffolding or staging more than 3.5 metres above the ground or floor shall have a guard rail properly attached, bolbraced and otherwise secured at least 0 metres above the floor or platform of such scaffolding or staging and extending along the entire length of the outside and ends thereof with only such opening as may be necessary for delivery of materials. Such scaffolding or staging shall be so fastened as to prevent it from swaying from the building or structure.
5. Scaffolds shall be so constructed that no part thereof can be displaced in consequence of normal use.
6. Scaffolds shall not be overloaded and so far as practicable the load shall be evenly distributed.
7. Before installing lifting gear of scaffolds special precautions shall be taken to ensure the strength and stability of the scaffolds.
8. Working platform, gangways and stairways should be so constructed that to part there can save unduly or unequally. If the height or the platform or the gangway or the stairways is more than 3.5 metres above ground level or floor level they should be closely boarded should have adequate width and should be suitably fenced as described in (4 above)
9. Every opening in the floor of a building or in a working platform shall be provided with suitable fencing or railing for a minimum height of 0.9 metre to prevent the fall of persons or material.
10. Safe means of access shall be provided to all working platforms and other working places. Every ladder shall be securely fixed. No portable single ladder shall be over 9 metres in length while the width between side rails in rung ladder shall in no case be less than 30cm for ladder up to and including 3 metres in length. For longer ladders this width should be increased at least 20 mm for each additional metre of length. Uniform step spacing should not exceed 30 cm. Adequate precautions should be taken to prevent danger from electrical equipment. No materials on the site of work shall be so stacked or placed as to cause danger or inconvenience to any person or the public. The contractor shall provide all necessary fencing and lights to protect the Public from accidents and shall be bound to bear the expenses of the defense of every suit, action or other proceedings at law that may be brought by any persons for injury sustained owing of the defense of

Contractor

Managing Director,
T.N.H.W.C.S.LTD, CHENNAI

every suit, action or other proceedings at law that may be brought by any persons for injury sustained owing to neglect of the above precautions and to pay any damages and cost which may be awarded in any such suit, action or proceedings to any which may be awarded in any such suit, action or proceedings to any such persons or which may with the consent of the contractor be paid to compromise and claim by any such person.

Excavation and trenching

11. Trenches -1.2 metres or more in depth, shall at all times be supplied with at least one ladder for each 30 metres in length or fraction thereof. Ladder shall be extended from bottom of the trench to at least 0.8 metre above the surface of the ground. The sides of trenches which are 1.5 metres or more in depth shall be stepped back to give suitable slope or hold securely by timber bracing, so as to avoid the danger of sides to collapse.

12. Demolition - Before any demolition is commenced and also during the process of the work -All roads and open areas adjacent to the work site shall either be closed or suitably protected.

a) No electric cable or apparatus which is liable to be a source of danger over a cable or apparatus used by the operator shall remain electrically charged.

b) All practical steps shall be taken to prevent danger to persons employed from risk or fire or explosion or flooding. No floor, roof or other part of the building shall be so overloaded with debris or materials as to render it unsafe.

Contractor

13. All necessary personal safety equipment as considered adequate by Departmental Engineer shall be kept available for the use of the person employed on the site and maintained in a condition suitable for immediate use and the contractor should take adequate steps to ensure proper use of equipment by those concerned.

a) Workers employed on mixing asphaltic materials cement and lime mortars shall be provided with protective footwear and protective goggles.

b) Those engaged in white-washing and mining or stacking of cement bags or any materials which is injurious to the eyes shall be provided with protective goggles.

c) Those engaged in welding works shall have protective goggles and protective clothing and seated at sufficiently safe intervals.

d) Those engaged in welding works shall be provided with welder's protective sight ligs.

e) When workers are employed in sewers and man holes which are in use, the contractor shall ensure that the manholes covers are opened and are ventilated at least for an hour before the workers are allowed to get into the manholes, and the manholes so opened shall be cordoned off with suitable railing and provided with warning signals or boards to prevent accident to the public.

f) The contractor shall not employ men below the age of 18 years and women on the

Managing Director,
T.N.H.W.C.S.LTD, CHENNAI

work of painting with products containing lead in any form. Wherever men above the age of 18 are employed on the work of lead painting, the following precautions shall be taken.

- (i) No paint containing lead and lead products shall be used except in the form of paste of ready-made paint.
- (u) Suitable face masks should be supplied for use by the workers when paint is applied in the form of spray or a surface having lead paint dry rubbed and scrapped.
- (in) Overalls shall be supplied by the contractors to workmen and adequate facilities shall be provided to enable the working painters to wash during the cessation of work.
- (iv) When workers are employed in dangerous occupations like work with hot bitumen, drilling operations etc., which are likely to prove dangerous resulting in physical amage and causality, adequate protection of the workers should be provided.

14. When the work is done near any place where there is risk of drowning all necessary equipments should be provided and kept ready for use and all necessary steps taken for prompt rescue of any person in danger and adequate provision should be made for prompt first aid treatments of all injuries likely to be sustained during the course of the works.

15. a) Hoisting machines and tackle including their attachments anchorages and supports shall be good mechanical

16. construction sound materials and adequate strength and free from patent defect and shall be kept in good repair and in good working order. Every rope used in hoisting or lowering materials or as a means of uspension shall be of suitable quality and adequate strength and free from patent defect.

b) Every crane driver or hoisting appliance operator shall be properly qualified and no person under the age of 21 years should be in control of any hoisting machine, including the scaffold winch or give signals to the operator.

c) In the case of every hoisting machine and of every chain ring hook shackle level and pully block used in hoisting or lowering or as a means of suspension, the safe working load shall be ascertained by adequate means. Every hoisting machine and all gear referred to above shall be plainly marked with the safe working load, in the case of hoisting machine having a variable safe working load, each safe working load and the conditions under which it is applicable shall be clearly indicated. No part of any hoisting machine or of any gear referred to above in this paragraph shall be loaded beyond the safe working load except for the purpose of testing.

16. Motors, gearing, transmissions, electric wiring and other dangerous parts of hoisting appliance shall be provided with efficient safeguards, Hoisting appliance shall be provided with such means as will request to a minimum the risk of the accidental descent of the load. Adequate precautions

shall be taken to reduce to a minimum the risk of any part of a suspended load becoming accidentally displaced.

When workers are employed on electrical installations which are already energized, insulating mats, wearing apparel such as gloves, sleeves and boots as may be necessary should be provided. The workers and carry keys or other materials which are good conductors or electricity.

17. These safety provisions should be brought to the notice of all concerned by display on a notice board at a prominent place at workshop. The person responsible for the compliance of the safety code shall be named by the contractor.

18. To ensure effective enforcement of the rules and regulations relating to safety precautions, the arrangements made by the contractor shall be open to inspection by the Labour Officer, Departmental Engineer of the Department or other representative.

19. Notwithstanding the above clauses (1) to (18) there is nothing in these to exempt the contractor from the operations of any other Act of rules in force in the Republic of India.

Model Rules for provision of Health and Sanitary arrangements for workers employed by the P. W.D. and Highways and Rural works Department and their contractors

The contractor's special attention is invited to relevant clauses of the "General conditions of contract" in the Tamilnadu Building Practice and he is requested to provide at his own expense the following amenities' to the satisfaction of Departmental Engineer.

Contractor

∴, Application : These rules shall apply to all building and construction works in charge of

2. Definition : (i) "Work place"¹¹ means a place at which an average fifty or more workers are employed in connection with construction work.

ii) "Large work place" means a place at which at an averaged 500 or more workers are employed in connection with construction work.

3. First Aid : (a) At the work site there shall be maintained in a readily accessible place, first aid appliance and medicines including an adequate supply of sterilized dressing. and sterilized cotton wool. The appliances shall be kept in good order. They shall be placed under the charge of a responsible person who shall be readily available during working hours.

(b) At large work places where hospital facilities are not available within easy distance of the works first-aid posts shall be established and be run by a trained compounded.

(c) Where large work places are remote from regular hospitals an in-door ward shall be provided with one bed for every 250 employees.

(d) Where large work places are situated in cities towns or in their suburbs and no beds are considered necessary owing to the proximity of city or town hospitals, suitable transport shall be provided to facilitate removal of urgent cases to these hospitals. At other work places some conveyance

Managing Director,
T.N.H.W.C.S.LTD, CHENNAI

facilities, such as a car shall be kept readily available to take injured persons or persons suddenly taken seriously ill to the nearest hospital.

4. Drinking Water :

a) Water of good quality fit for drinking purposes shall be provided for the work people on a scale of not less than 15 litres per head per day.

b) Where drinking water is obtained from an intermittent public water supply each work place shall be provided with storage tank where such drinking water shall be stored.

c) Every water supply storage shall be at a distance of not less than 15 metres from any latrine, drain or other source of pollutions. Where water has to be drawn from an existing well, which is within such proximity of latrine, drain or any other source of pollution, the well shall be properly chlorinated before water is drawn from it for drinking. All such wells shall be entirely closed in and be provided with a trap door which shall be dust and water proof.

d) A reliable pump shall be fitted to each covered well the trap door shall be kept locked and opened only for cleaning or inspection which shall be done atleast once a month.

5. Washing and bathing places : Adequate washing and bathing places should be provided, separately for men and women such places shall be kept in clean and drained condition.

Bathing or washing should not be allowed in or near any drinking water well.

6. Latrines and Urinals: There shall be provided within the precincts of every work Contractor

place, latrines and urinals in an accessible place and the accommodation, separately for each of them, shall be on the following scale or on the scale so directed by Departmental Engineer in any particular cases.

(i) Where the number of persons employed does not exceed 50 2 seats

(ii) Where the number of persons employed exceed 50 but does not exceed 100 3 seats

(iii) For every additional 100 3 seats

If women are employed separate latrines and urinals screened from those for men shall be provided on the same scale.

Except in work places provided with water flushed latrines connected with a water borne sewage system, all latrines shall be provided with receptacle on a dry earth system which shall be cleaned at least four times daily and at least twice during the working hours and kept in strictly sanitary conditions. The receptacles shall be tarred inside and outside atleast once a year.

The excreta from the latrines shall be disposed off at the contractor's expense, in outway pits approved by the local Public Health Authority. The contractor shall also employ adequate number of scavengers and conservancy staff to keep the latrines and urinals in a clean condition.

7. Shelters during rest : At every work site there shall be provided free of cost, two suitable sheds one for meals and the other for rest separately for men and women for the use of labourers.

8. Creches: (a) At every workplace at which 50 or more women workers are ordinarily employed, there shall be provided two huts of suitable size for the use of children under age of 6 years belonging to such women, one hut shall be used for infants games and play and the other as a bed room. The huts shall not be constructed on a lower standard than the following

- i) Thatched roofs
- ii) mud floors and walls.
- iii) Planks spread over the mud floor and covered with matting.

The huts shall be provided with suitable and sufficient opening for light and ventilation. There shall be adequate provision of sweepers to keep the places clean. There shall be two Dais in attendance. Sanitary utensils shall be provided to the satisfaction of the Health Officer of the area concerned.

The use of the huts shall be restricted to children, their attendants and mothers of the children.

b) Where the number of Women workers is more than 25 hut less than 50, the contractor shall provided atleast one hut and one Dai to look after the children of women workers.

c) The size of crèche or crèches shall vary according to number of women workers.

d) The crèche of crèches shall be properly maintained and necessary equipment like toys, etc., shall be provided.

9. **Canteens** : A cooked food canteen on a moderate scale shall be provided for the benefits of workers if it is considered expedient

10. Sheds for workmen : The contractor should provide at his own expense shed? for housing his workmen. The.se sheds shall be on a standard not less than the cheap shelter type, to live in which the work people in the locality are accustomed to.

A floor area of about 1.8 metres x 1.5 metres for two persons shall be provided. The sheds to be in rows with 1.3 metres clear space between sheds and a 9 metres clear space between rows if conditions permit. The work people's camp shall be laid out in units of 400 persons, each, each unit to have a clear space of 12 metres around.

APPENDIX – IX- XXXVIII
MONTHLY REPORT OF CONSTRUCTION EMPLOYEES
UNDER CONTRACTORS

1. Name, location and type of work
2. Name of Contractor
3. Works engaged in
 - (i), Work
 - (ii) Government work other than PWD (iii) Other works
4. Name and address of Manager(s) of works
5. Value of contract
6. Employment earnings

Category	Men	Women	Employees boys	Girls
1	2	3	4	5

- I. Total number of employees during months:
 - II. Number of employees in the works on the last working day of the month:
 - EL. Total wages paid for
 - IV. Total numbers of working days during the month
 - V. Length of normal wage period
- Date : Place :
To

Signature of the Contractor or
Manager

1. The Employment Officer, District Employment Office,
2. Engineer,

Contractor

Managing Director,
T.N.H.W.C.S.LTD.,CHENNAI.

Instruction to complete the Proforma

1. The Contractor means the person who has contracted to execute the works.
2. Manager means any person who manages, supervises the work(s) on behalf of the contractor.
3. Item-6(i) The cumulative total of daily employment on all days in a Calendar month, if the last day of the Calendar month is a holiday, the working day immediately previous to the holiday. Item 6 (ii) Wages means basic wage, dearness allowance project allowances etc. including work benefits paid in cash or kind.
Item 6 (iii) Columns 2 and 3 refer to adults who are 18 years of age or over. Item 6 - Columns 4 and 5 refer to others not covered by columns 2 and 3.
4. Returns should cover a calendar month.
5. Completed returns to reach the employment exchanges concerned on or before 5th of the monthsucceeding the month to which the return relates.

Contractor

Managing Director,
T.N.H.W.C.S.LTD.,CHENNAI.

**ABRACT IMATE FOR CONSTRUCTION OF COMMERCIAL BUILDING AT CO OPTEX
REGIONAL OFFICE AT THIRUNELVELI REGION.(stilt +first floor only)**

Sl. No.	Quantity	Description	Rate in rupees	Unit in Figures and in words	Amount in rupees
1	185	Earth work excavation for foundation in all soils and sub-soils and to full depth as may be directed except in rock requiring blasting inclusive of shoring shuttering, bailing out water wherever necessary and depositing the surplus earth within the compound in places shown by the departmental officers with an initial lead of 10 mts and initial lift of 2 mts. and clearing and levelling the site, etc., complete complying with standard specification.		1 cu.m (One cubic metre)	
2	300	Labour Charges for boring the 45 cm dia pile bore with power equipments including transport, fuel, all labour charges for making the bore holes etc., complete with standard specification.		1 R.m (One Running metre)	
3	850	Supplying and filling in foundation, basement, etc with Conveyed Earth in layers of not more than 15 cm thick well watered, rammed and consolidated etc. complete complying with standard specification and as directed by the departmental officers.		1 cu.m (One cubic metre)	
4	110	Refilling with excavated earth other than sand with an initial head load of 100 mts. and depositing the earth as shown by the departmental officers in layers of not more than 15 cm thick well rammed, watered and consolidated etc. complete complying with standard specification		1 cu.m (One cubic metre)	

Contractor

Managing Director,
T.N.H.W.C.S.LTD.,CHENNAI.

5	25	Supplying and filling in foundation, basement, etc with filling sand including loading and unloading at site and laid in layers of not more than 15 cm thick well watered, rammed and consolidated etc. complete complying with standard specification and as directed by the departmental officers		1 cu.m (One cubic metre)	
6	90	Cement Concrete 1:5:10 (One Cement, Five sand and Ten hard broken stone jelly) using 40 mm gauge hard broken granite stone jelly for foundation including dewatering wherever necessary and laid in layers of not more than 15 cm thick well rammed, consolidated and curing etc. complete complying with standard specification		1 cu.m (One cubic metre)	
7		Brick work in following Cement Mortar using best quality of country bricks of size 8-3/4" x 4-1/4" x 2-1/4" for foundation and basement including curing, etc., complete complying with standard specification.			
A	65	In foundation and basement		1 cu.m (One cubic metre)	
B	67	In Stilt		1 cu.m (One cubic metre)	
C	86	In First floor		1 cu.m (One cubic metre)	

8		Supplying and erecting centering for sides and soffits including necessary supports and strutting upto 3.29 M height for plane surfaces as detailed below in all floors with all cross bracings using Mild Steel sheets of size 90 x 60 cm and 10 BG stiffened with welded Mild Steel angle of size 25mm x 25mm x 3 mm for boarding laid over silver oak joists of size 10cm x 6.50 cm spaced at abote 90 cm centre to centre and supported by casurina props of 10cm to 13 cm dia spaced at not more than 75 cm centre to centre etc. complete complying with the standard specificalton. (Payment for centering shall be given after the concrete is laid)			
A	106	For plane surfaces such as grade beam , etc.complete.		1 sq.m. (One square metre)	
B	1800	For plane surfaces such as RCC lintel beam,sunshade,roof beam,roof slab,waist slabs etc.		1 sq.m. (One square metre)	
C	270	For plane surfaces such as rectangular or square RCC columns, sunshades, top and bottom slab of RCC boxing, etc.		1 sq.m. (One square metre)	

9		Cement Concrete 1:1-1/2:3 (One Cement, One and a half sand and Three hard broken stone jelly) using 20 mm gauge hard broken granite stone jelly for all RCC items of works excluding cost of reinforcement grill and fabricating charges centering and shuttering but including laying, vibrating with mechanical vibrators, finishing, curing, etc. and providing fixtures like fan clamps in the RCC floor / roof slabs wherever necessary and bearing surfaces of walls, beams etc. shall be finished smooth with Cement Mortar 1:3 (One Cement and Three Sand) and kraft paper laid over it without claiming extra, etc., complete complying with standard specification and as directed by the departmental officers			
A	150	In foundation and basement		1 cu.m. (One cubic metre)	
B	105	In stilt floor		1 cu.m. (One cubic metre)	
C	110	In First floor		1 cu.m. (One cubic metre)	
10	520	Supplying, fabricating and placing in position Mild Steel / Ribbed Tor Steel grills for all RCC works as per design given including cost of steel and G.I. binding wire in all floors etc. complete complying with standard specification. (Contractor has to make his own arrangements for the supply of steel and binding wire)		1 Qtl. (One quintal)	
11	2	Plain Cement Concrete 1:2:4 (one cement, two sand and four hard broken stone jelly) using 20mm jelly for wearing coat including laying, compacting, finishing and curing, etc., complete as per standard specificatins and as directed by the departmental officers.		1 cu.m. (One cubic metre)	

Contractor

Managing Director,
T.N.H.W.C.S.LTD.,CHENNAI.

12		Providing granolithic floor finish of the following thickness with plain cement concrete 1:2:4 (One Cement, Two sand and Four aggregate) using 10 to 12mm gauge hard broken stone jelly including laying, finishing and the top rubbed smooth with power trawl, thread lining, curing etc. complete complying with standard specification and as directed by the departmental officers. (The rate is inclusive of necessary planking for panelling wherever necessary and as directed by the departmental officers)			
A	410	40mm thick		1 sq.m. (One square metre)	
13		Brick partition walls of 11.50cm thickness using best quality II class table moulded chamber burnt bricks of size 9" x 4-1/2" x 3" in Cement Mortar 1:3 (One Cement and Three Sand) using hoop iron reinforcement if found necessary including curing etc. complete and as directed by the departmental officers. (Hoop iron reinforcement will be measured and paid for separately)			
A	70	In First Floor		1 sq.m. (One square metre)	
14	550	Paving the floor with best quality vetrified Tiles of size 600 x 600 x 8mm of approved colour, shade and quality laid in cement mortar 1:3 (one cement and three sand) 20mm thick in all floors and the top pointed with the white cement mixed same colour pigments etc., complete complying with standard specification. (The make and brand of the tiles should be got approved by Engineer before use on works)		1 sq.m. (One square metre)	

Contractor

Managing Director,
T.N.H.W.C.S.LTD.,CHENNAI.

15	20	Paving the floor with pre-polished concrete anti-skid tiles (Required shape and design) of 20mm thick of approved quality and colour laid in Cement Mortar 1:3 (One Cement and Three sand) 20mm thick and pointed with white cement mixed with colouring pigment at the rate of 0.40 Kg. / sq.m., curing, etc., complete complying with standard specification and as directed by the departmental officers. (The make and brand of the tiles should be got approved by Engineer before use on works)		1 sq.m. (One square metre)	
16	185	Paving the floor with pre-polished concrete anti-skid step tiles (Required shape and design) of 20mm thick of approved quality and colour laid in Cement Mortar 1:3 (One Cement and Three sand) 20mm thick and pointed with white cement mixed with colouring pigment at the rate of 0.40 Kg. / sq.m., curing, etc., complete complying with standard specification and as directed by the departmental officers. (The make and brand of the tiles should be got approved by Executive Engineer before use on works)		1 sq.m. (One square metre)	
17		Dadoing walls with following best approved quality, white / colour glazed tiles of following sizes set in Cement Mortar 1:2 (One Cement and Two sand) 10mm thick and pointing the joints with white cement mixed with colouring pigments at the rate of 0.40 Kg. / sq.m. neatly in all floors, curing, etc., complying with standard specification and as directed by the departmental officers.			
A	150	Dadoing with printed design colour glazed tiles of size 150mm x 150mm x 6mm		1 sq.m. (One square metre)	

18		Supplying and fixing in position best approved of BIS quality PVC rain water down fall pipes having a pressure of 4 kg. / sq.cm including cost of necessary PVC shoe, PVC bend, cast iron gratings of required diameter and special clamps, brass screws, nails, etc., and fixing of cast iron gratings at junction of parapet and the RCC roof slab including finishing neatly etc., complete. The rate shall be inclusive of cast of removable cast iron grating. The PVC pipe shall be fixed in wall with special type of "U" clamp at the centre of the pipe line in addition to those for more than 3.0 metre pipe length, etc., complete complying with standard specification.			
19	1	Providing wood work in frames of doors wrought framed and fixed in position complete complying with standard specification		1 cu.m. (One cubic metre)	
20	20	Providing and fixing 4solid flush door shutter with teak wood ply on both side with teak wood lipping around 35mm thick including all hardware materials and labour charges.		1 sq.m. (One square metre)	

21	22	<p>UPVC Window Specification: Supplying and fixing UPVC (Un-Plasticized Polyvinyl Chloride) Windows of casement type (open) from the profile the size of outer frame 60mm x 58mm and shutter profile are reinforcement with GI/1mm 125GSM and 100% corrosion free, the profiles are multi chambered sections with wall thick of 2mm. The EPDM rubber (black colour) covered with over all the edges of frame and shutter the shutter will be provided with Espag multi power point locks and also it operates as handle. The corners and joints should be welded and cleaned. Radiations free pin headed plain or brown colour glass 4mm thick should be provided to the shutter and it should not allow leakage of water even at most ranging storms and should have key lockable action, security protective hinges, strong locking systems and as per size for arresting noise and energy loss. The connecting mechanism between sash and outer frame that enables opening of the window. The window should be fixed to the wall with 100% packing with screws and silicon packing all round the frames. The window should be got approved from the Engineer before use on work</p>		1 sq.m. (One square metre)	
----	----	--	--	-------------------------------	--

22	4	<p>UPVC Ventilator Specification: Supplying and fixing UPVC (Un-Plasticized Polyvinyl Chloride) Louvered Ventilators of from the profile the size of outer frame 60mm x 58mm and shutter profile size of 60 x 78mm both profiles are reinforced with GI/1mm 125GSM and 100% corrosion free, the profile are multi chambered sections with wall thick of 2mm. The EPDM rubber (black colour) covered with all over the edges of frame and shutter. The corners and joints should be welded and cleaned. Radiations pin headed glass 4mm thick should be provided in the louvers. The window should be fixed to the wall with 100% packing with screws and silicon packing all round the frames. The ventilator should be got approved from the Executive Engineer before use on work</p>		1 sq.m. (One square metre)	
23	500.00	<p>Supplying and fixing mild steel iron grill for Windows Ventilators and grill gate etc., including one coat of red oxide primer using M.S. angle of size 40x40x6mm and grill using 20x6mm MS flat and necessary hold fast with M.S. angle of size of 40x40x6mm - 230mm long spliced at end is to be provided appropriate places for fixing the grill etc complete complying with standard specification. The type design for the grills should be got approved by the departmental officers before execution.</p>		1 Kg (One Kilo Gram)	

24	13	Solid PVC door shutters using 19 Gauge 19mm MS square tubes for styles and outer frames. 15mm MS square tubes for top, lock and bottom rails. The steel tubes shall be covered with 5mm thick solid PVC sheets. Shutter using 5mm thick solid PVC sheets for panelling shall rigidly fixed in position including necessary furniture and fittings. The over all size of styles shall be 50mm x 30mm. The over all size of top rail, Lock rail and bottom rail shall be 75mm x 30mm. The over all size of frames shall be 50mm x 45mm, with suitable rabate for housing the shutter.		1 sq.m. (One square metre)	
25	120	Manufacturaing Supplying and fixing of Stainless steel Hand Rails for staircase using 50mm dia 304 L Grade Stainless steel pipe of 1.0 mm thick as verical at 900 mm centre with 2 Nos of 25 mm diameter intermediate harisontal stainless steel pipe of 1.60mm thick between . The Vertical pipe has to be welded to the 100 x 100 x 6 mm MS Base plate encased in the base concrete. The rate is inclusive of charges fir cutting , bending, welding, grinding, polishing, conveyance, electrical charges etc., complete complying with standard specification and as directed by the officers.		1 RM. (One running metre)	
26	3000	Plastering with Cement Mortar 1:5 (One cement and Five sand), 12mm thick in all floors including curing etc. complete complying with standard specification and as directed by the departmental officers.		1 sq.m. (One square metre)	
27	1500	Plastering with Cement Mortar 1:5 (One cement and Five sand), 20mm thick in all floors including curing etc. complete complying with standard specification and as directed by the departmental officers.		1 sq.m. (One square metre)	

28	2700	Special ceiling plastering and finishing the exposed surface of all RCC items of work such as slabs, beams, sunshades, facia, canopy slab, staircase waist slab, landing slab etc., with Cement Mortar 1:3 (One Cement and Three Sand) 10mm thick including hacking the surfaces, providing cement mortar nosing, beading for sunshades, staircases, steps, landing slabs and curing, etc., in all floors complying with standard specification and as directed by the departmental officers		1 sq.m. (One square metre)	
29	410	Plastering with Cement Mortar 1:3 (One Cement and Three Sand) 20mm thick mixed with water proofing compound conforming to BIS at 2% by weight of cement used including finishing, curing, etc., complete in all floors complying with standard specification and as directed by the departmental officers.		1 sq.m. (One square metre)	
30	6500	White washing one coat with freshly burnt white shell lime in all floors including cost of lime, blue powder, fevicol type gum, brushes, scaffolding charges, etc., complete complying with standard specification and as directed by the departmental officers.		1 sq.m. (One square metre)	
31	1200	Supplying and painting the walls with two coats of cement paint over one coat of cement primer as instructed by the departmental officers including preparation of surface curing, etc., complete in all floors complying with standard specifications (The colour and shade of the cement paint shall be got approved by the Engineer before use of work)		1 sq.m. (One square metre)	

32	4500	Painting two coats of newly plastered wall surface with ready mixed plastic Exterior/interior emulsion paint of first class quality and of approved colour over a priming coat including thorough scrapping, clean removal of dirt, and including necessary plaster of paris putty, wherever required etc., complete complying with standard specification.		1 sq.m. (One square metre)	
33	70	Painting new wood work with two finishing coats of synthetic enamel ready mixed paint of approved quality and colour over one coat priming coat in all floors including the cost of primer etc., complete complying with standard specification. (The make, quality and colour of paint should be got approved by the Engineer before use on works.)		1 sq.m. (One square metre)	
34	60	Painting new iron works such as steel doors, windows, ventilators, window bars, balustrades etc., with two coats of best approved first quality and colour of synthetic enamel paint over the existing red oxide priming coat in all floors including cost of priming coat etc., complete complying with standard specification. (The make, quality and colour of paint should be got approved by the Engineer before use on works.)		1 sq.m. (One square metre)	
35	50	Polishing the teak wood door with two coats of best French (Lac) polish with approved quality and brand over a coat of bee's waxing including preparing the wooden surface to receive polishing, etc., complete complying as per the standard specifications. (The make, quality and colour of french polish, bees vax should be got approved by the Engineer before use on works.)		1 sq.m. (One square metre)	

36	30	Supplying and erecting pull and Push Type rolling Shutterswith ISI make of approved size and section using 18 GI sheet. The Shutter shall be painted with one coat of red oxide primer and the rate is inclusive of hood covers transportation charges etc.		1 sq.m. (One square metre)	
		Total			
		GST 18%			
		Grand Total			

Contractor

Managing Director,
T.N.H.W.C.S.LTD.,CHENNAI.

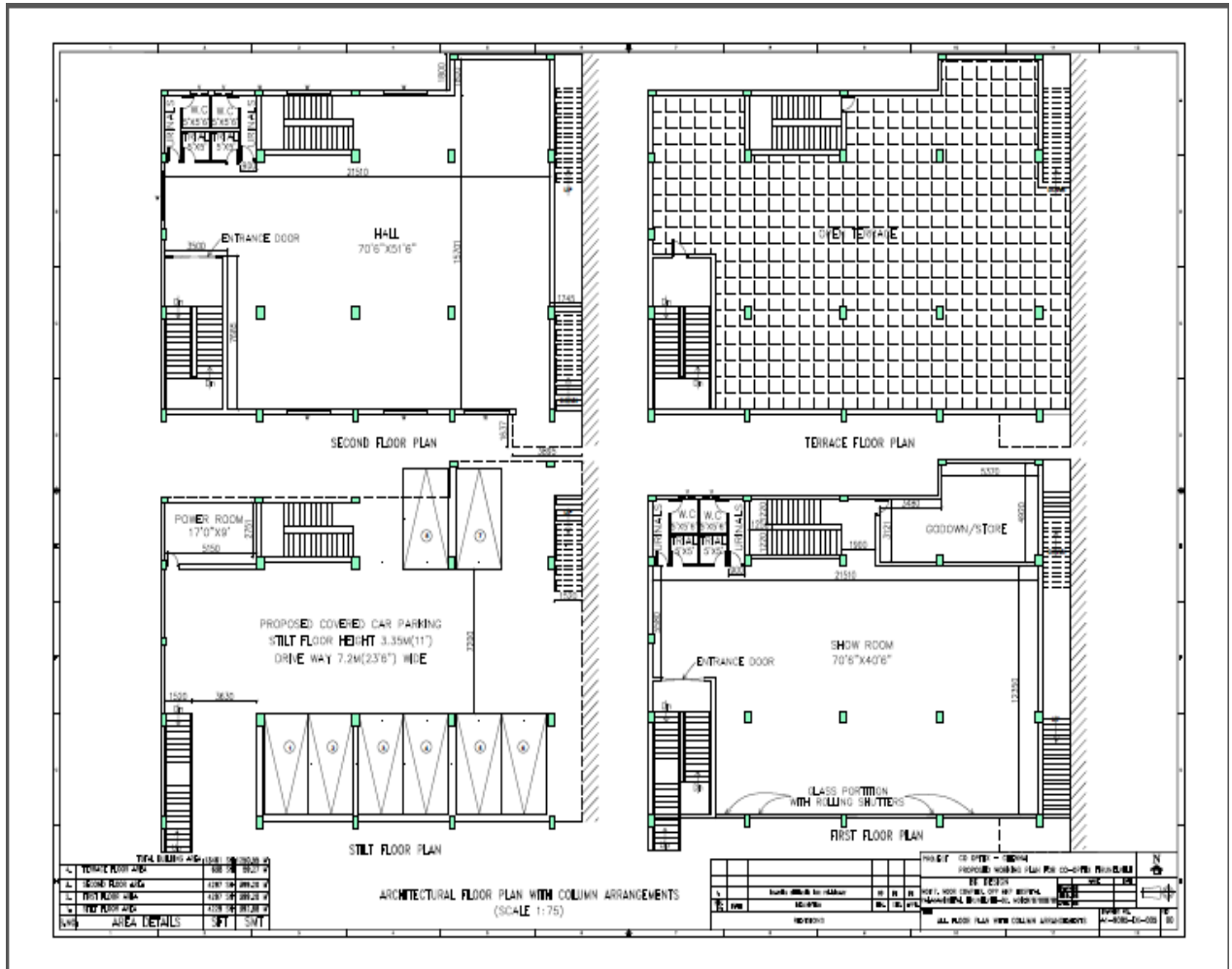

Contractor

Managing Director,
T.N.H.W.C.S.LTD.,CHENNAI.

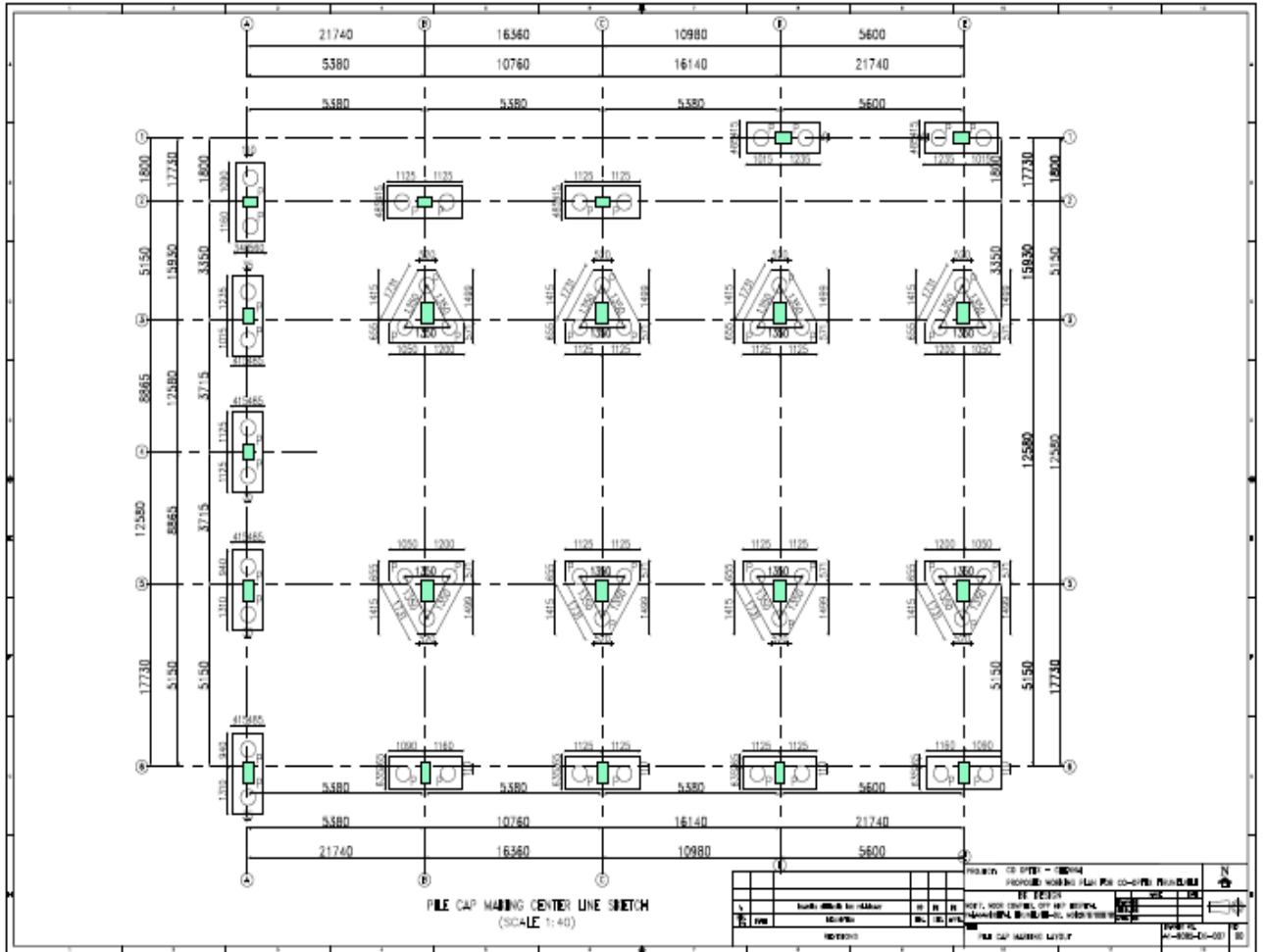

Contractor

Managing Director,
T.N.H.W.C.S.LTD.,CHENNAI.

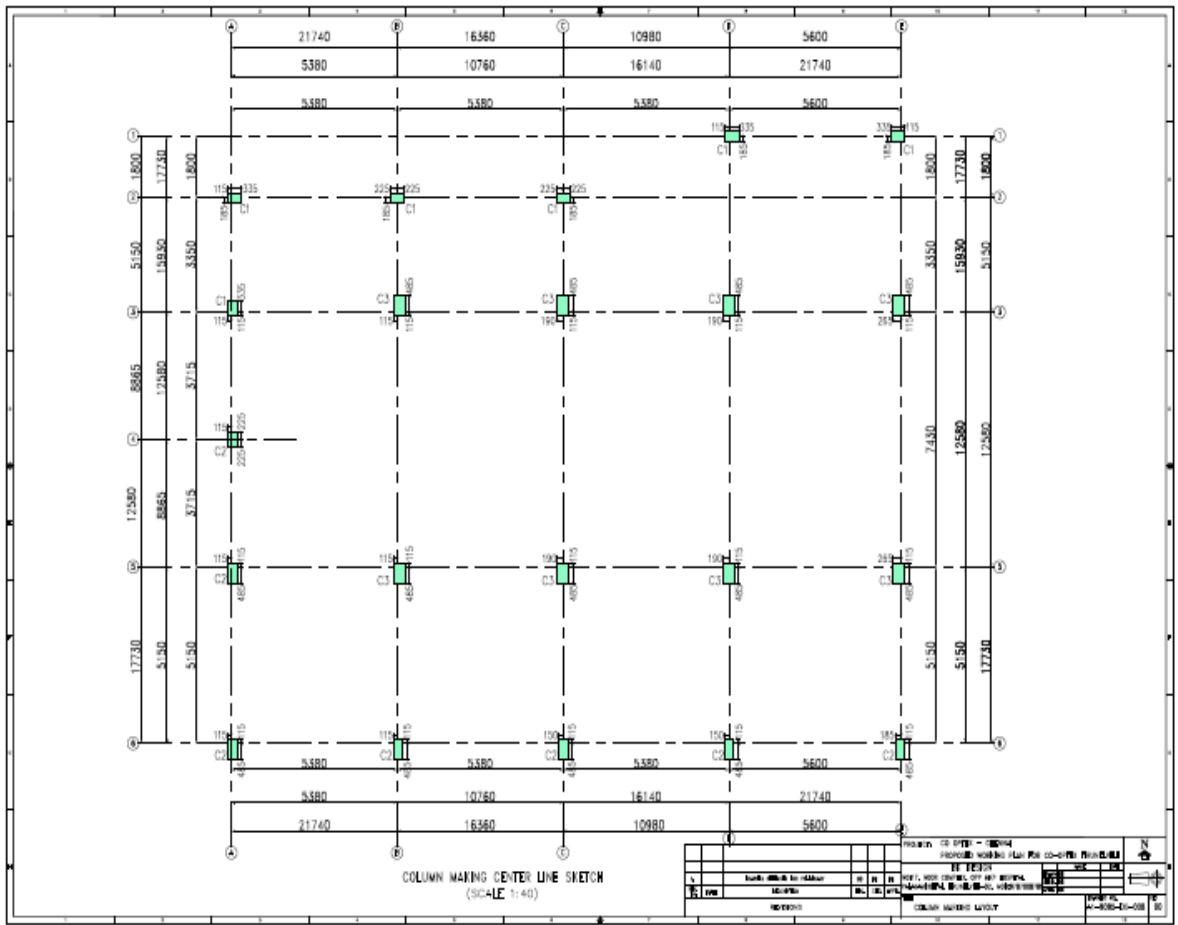

Contractor

Managing Director,
T.N.H.W.C.S.LTD.,CHENNAI.

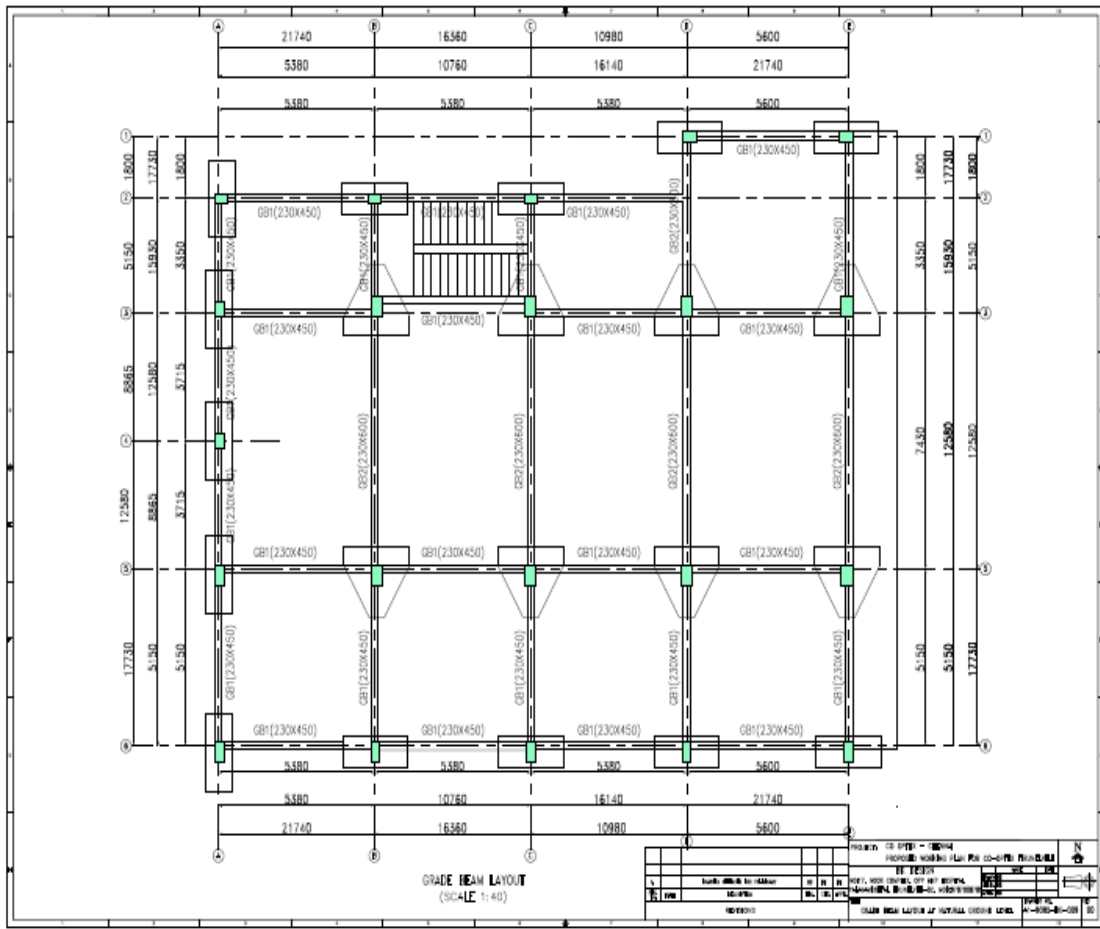

Contractor

Managing Director,
T.N.H.W.C.S.LTD.,CHENNAI.

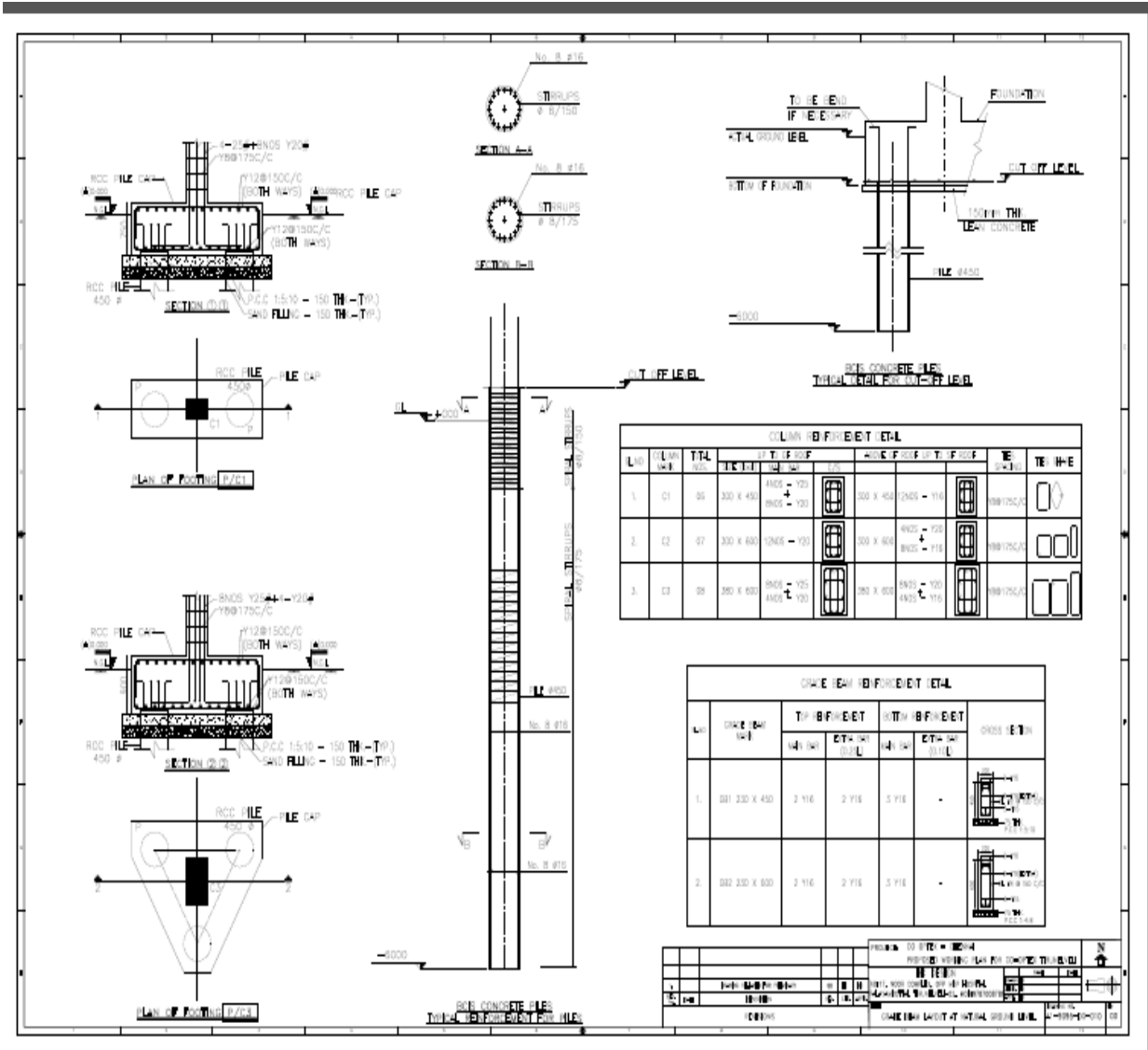

Contractor

Managing Director,
T.N.H.W.C.S.LTD.,CHENNAI.

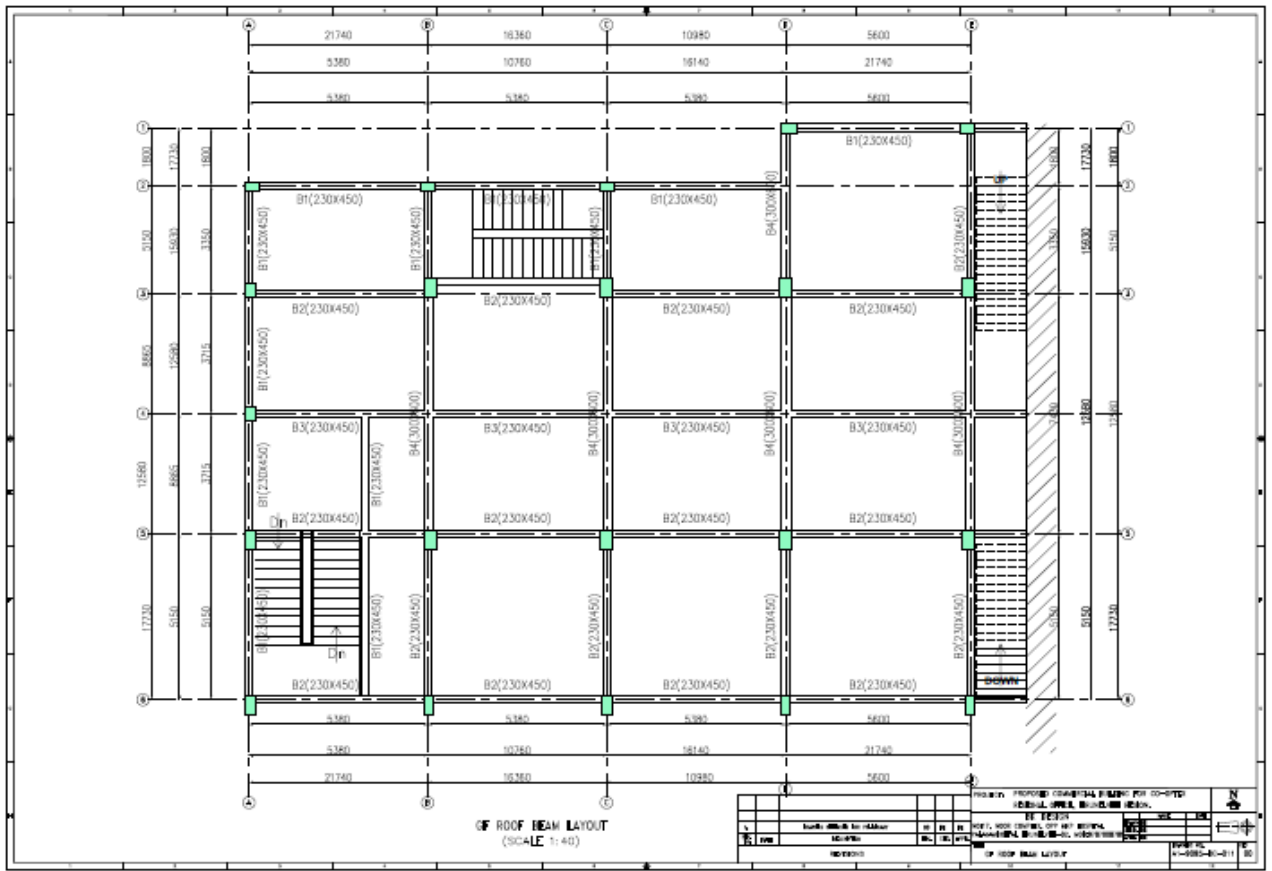

Contractor

Managing Director,
T.N.H.W.C.S.LTD.,CHENNAI.

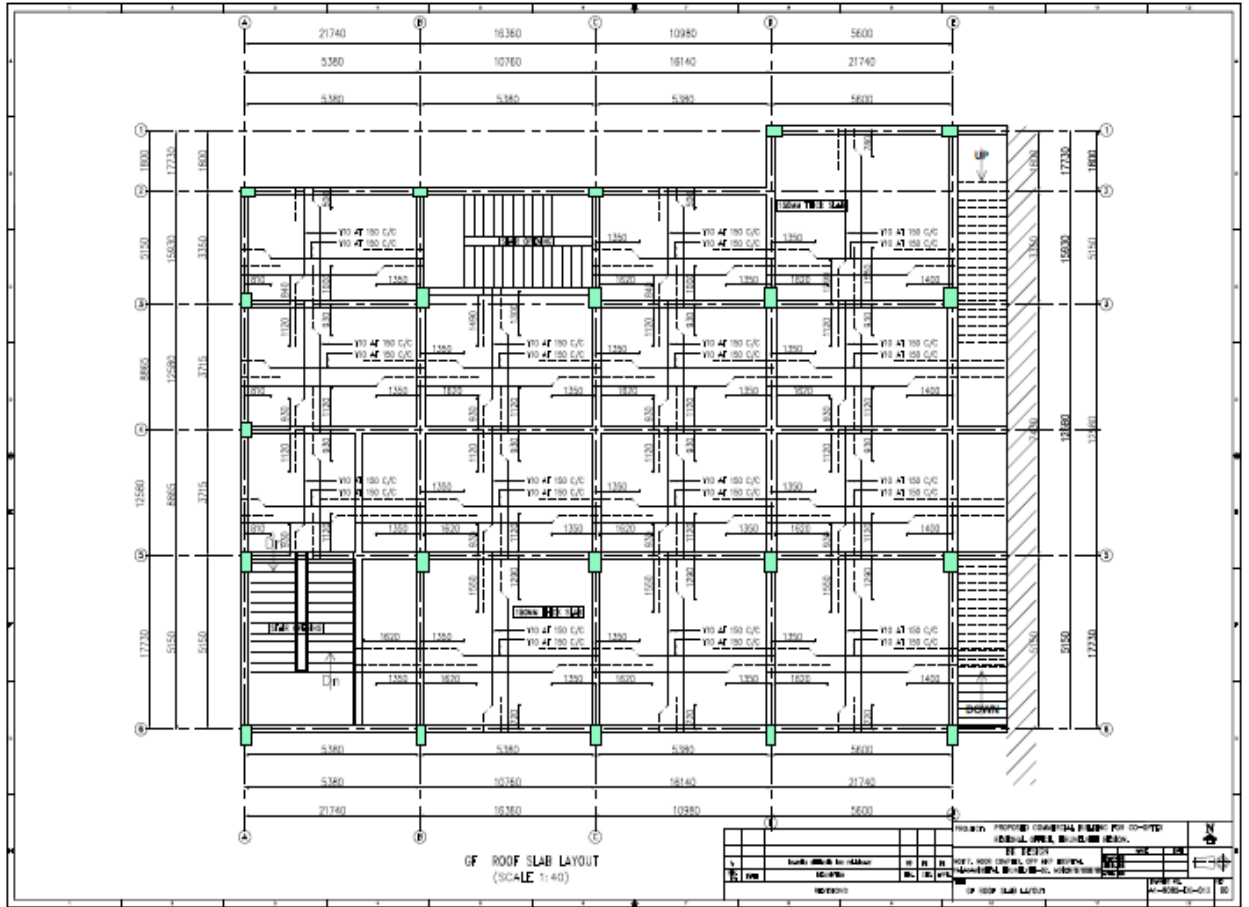

Contractor

Managing Director,
T.N.H.W.C.S.LTD.,CHENNAI.

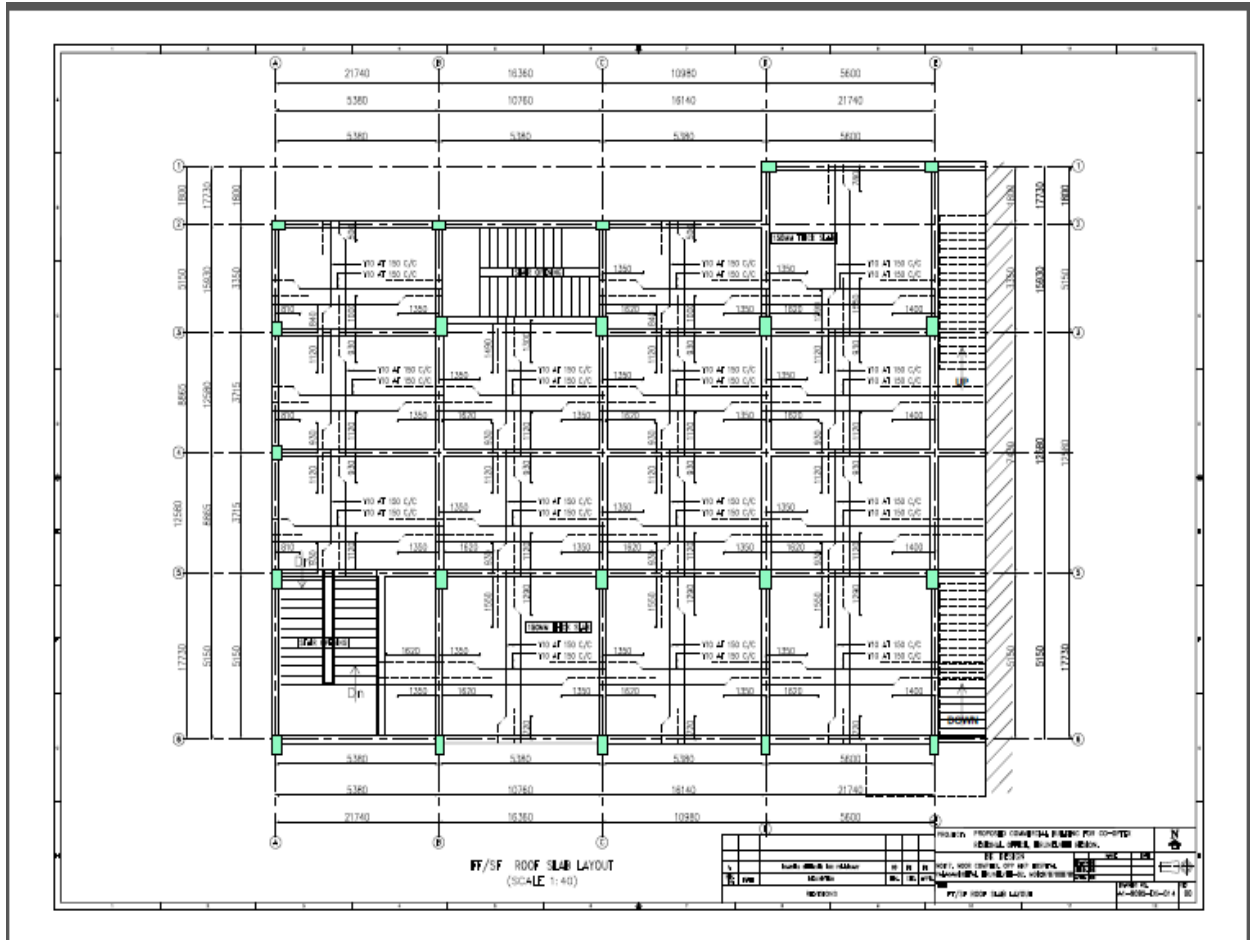

Contractor

Managing Director,
T.N.H.W.C.S.LTD., CHENNAI.

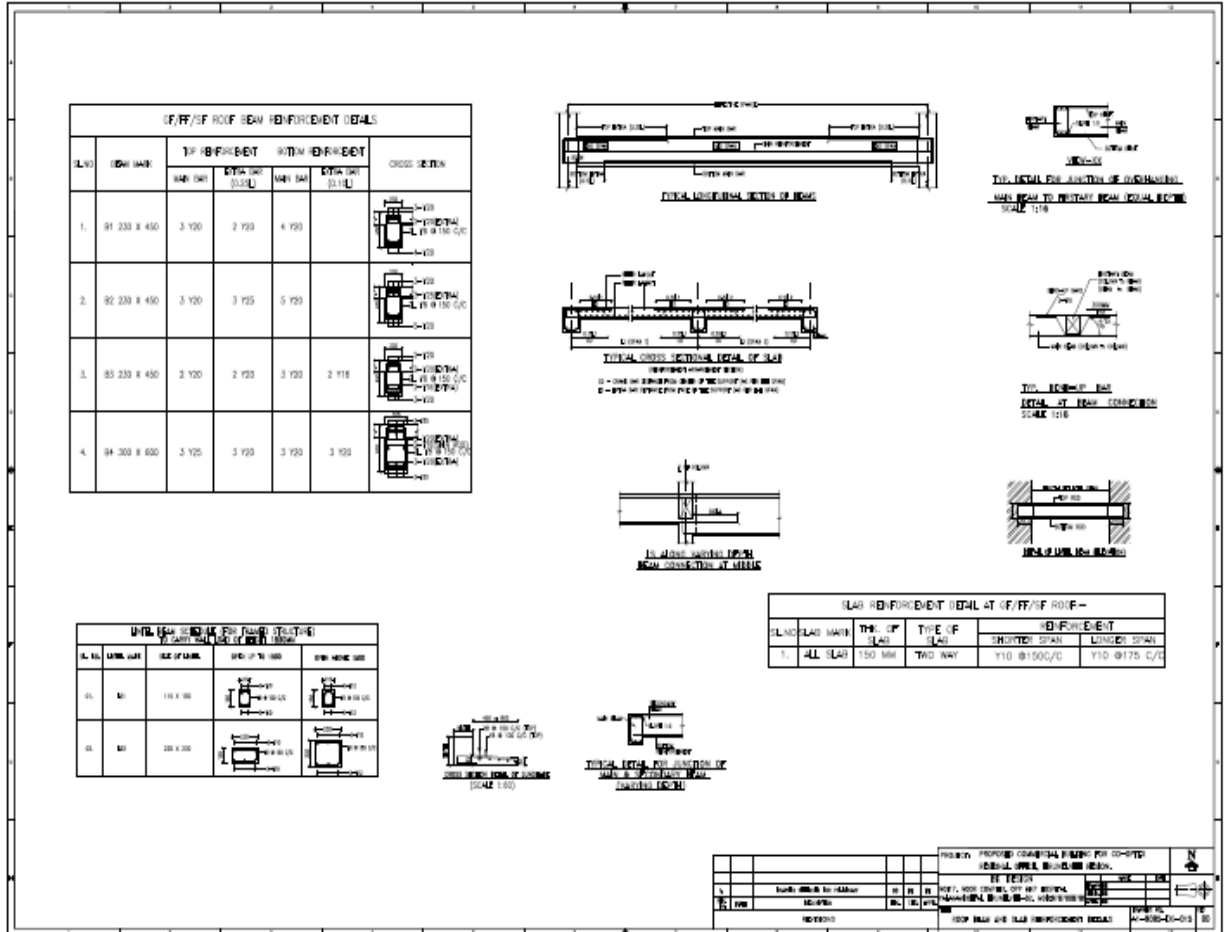

Contractor

Managing Director,
T.N.H.W.C.S.LTD.,CHENNAI.